



Drainage pumps for charged liquids with set-back Vortex type impeller for civil and industrial applications; specifically designed for very heavy use; available in the mobile or permanent versions with coupling feet.



Construction features

Pump body cast iron



Impeller cast iron

Mechanical seal

double seal with oil barrier:
silicon carbide on pump side,
ceramic-graphite on motor
side

Motor shaft stainless steel AISI 304

Free passage

Ø max 50 mm (160-310; 750-1000)
Ø max 45 mm (400-550)

Max submergence 20 m

Liquid temperature 0 - 40 °C

Cable H07 RN8F, 10 m

Bolts A2 stainless steel

Foot support galvanized iron

Gaskets NBR rubber

Motor

3~ 230V-50Hz
3~ 400V-50Hz
3~ 230/400V-50Hz
3~ 400/690V-50Hz

2 Poles induction motor

1- 230V-50Hz
required run capacitor (35µF
for 1,5HP model, 50µF for
2HP model)

Insulation class F

Protection degree IPX8

TYPE	LOTS			
	TRUCK		CONTAINER	
	PALLET (cm)	N° pumps	PALLET (cm)	N° pumps
DV 160-310	85×110×145	18	85×110×190	27
DVT 400-550	85×110×170	12	85×110×170	12
DVT 750-1000	100×120×190	12	100×120×190	12

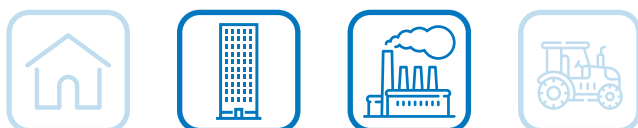

DV

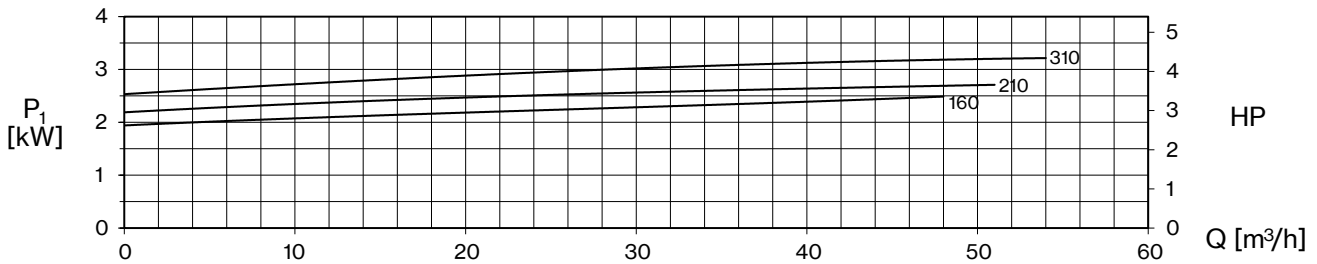
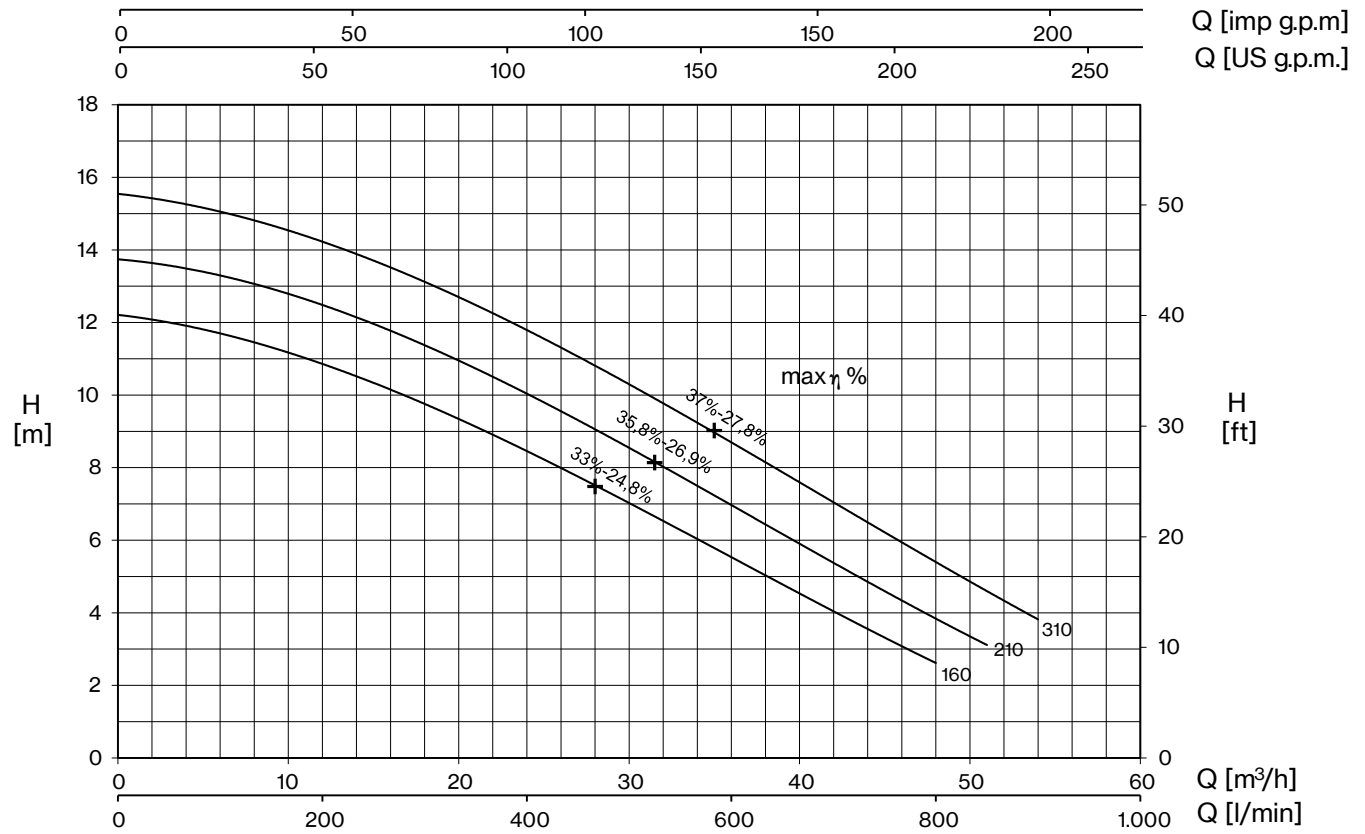

TYPE		AMPERE				
1~	3~	230 V 50 Hz	3x230 V 50 Hz (*)	3x400 V 50 Hz	230/400 V 50 Hz λ / Δ (*)	400/690 V 50 Hz λ / Δ
DV 160	DVT 160	11,3	7,1	4,1	-	-
DV 210	DVT 210	12,6	8,7	5	-	-
-	DVT 310	-	9,9	5,7	-	-

+ max η %

max hydraulic efficiency and respective total efficiency

(*) no standard execution

TYPE		P ₂		P ₁ (kW)		Q (m³/h - l/min)							
1~	3~	HP	kW	1~	3~	0	12	24	36	42	48	51	54
						0	200	400	600	700	800	850	900
						H (m)							
DV 160	DVT 160	1,5	1,1	2,5	2,3	12,2	10,9	8,4	5,6	4,1	2,6		
DV 210	DVT 210	2	1,5	2,8	2,7	13,7	12,6	9,9	7,0	5,4	3,8	3,1	
-	DVT 310	3	2,2	-	3,3	15,5	14,4	11,6	8,8	7,1	5,4	4,5	3,8



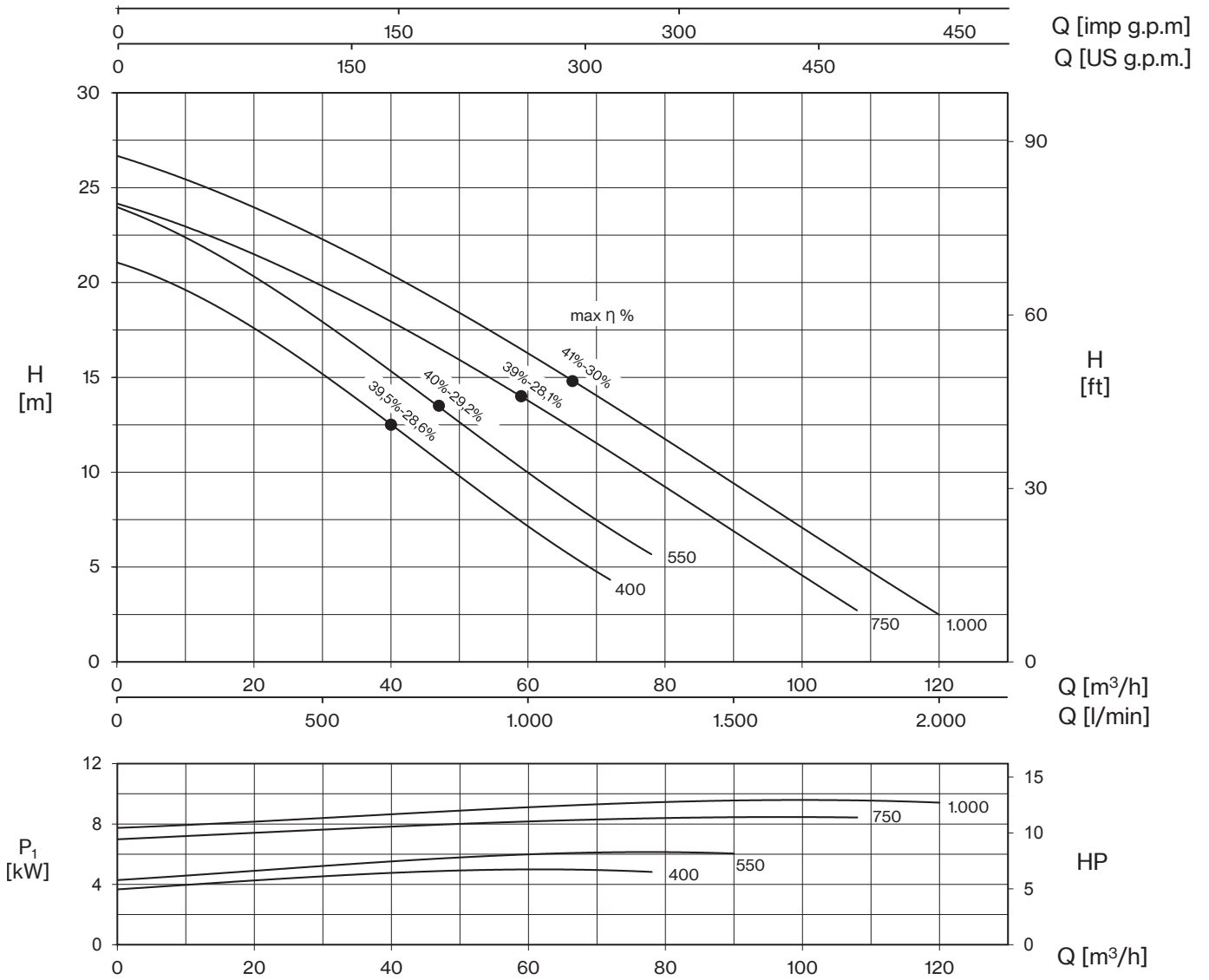

TYPE	AMPERE			
	3x230 V 50 Hz (*)	3x400 V 50 Hz	230/400 V 50 Hz λ / Δ (*)	400/690 V 50 Hz λ / Δ
DVT 400	14,1	8,1	-	-
DVT 550	18,1	10,4	-	-
DVT 750	-	14,4	25	14,4
DVT 1000	-	16,4	28,5	16,4

+ max η %

max hydraulic efficiency and respective total efficiency

(*) no standard execution

TYPE	P2		P1 (kW)	Q (m³/h - l/min)																
				0	12	24	36	42	48	51	54	60	72	78	84	90	96	108	114	120
	HP	kW	3~	0	200	400	600	700	800	850	900	1000	1200	1300	1400	1500	1600	1800	1900	2000
DVT 400	4	3	4,9	21,0	19,4	16,6	13,5	12,0	10,4	9,6	8,8	7,2	4,3	2,8						
DVT 550	5,5	4	6,1	23,9	22,2	19,3	16,3	14,8	13,2	12,4	11,6	10	7,1	5,6	4,1	2,6				
DVT 750	7,5	5,5	8,5	24,2	22,7	20,7	18,7	17,6	16,4	15,8	15,2	13,9	11,1	9,7	8,2	6,8	5,4	2,8		
DVT 1000	10	7,5	9,6	26,7	25,2	23,2	21,2	20,0	18,8	18,2	17,6	16,3	13,7	12,3	10,8	9,4	8,0	5,1	3,8	2,6



DV

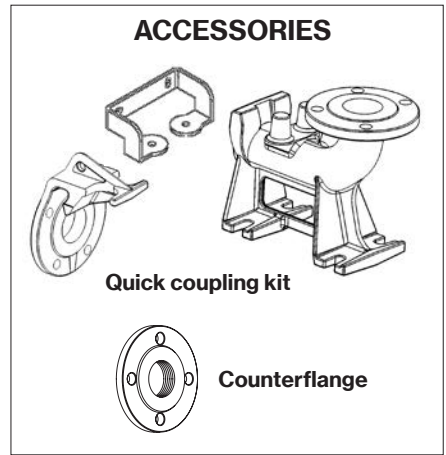
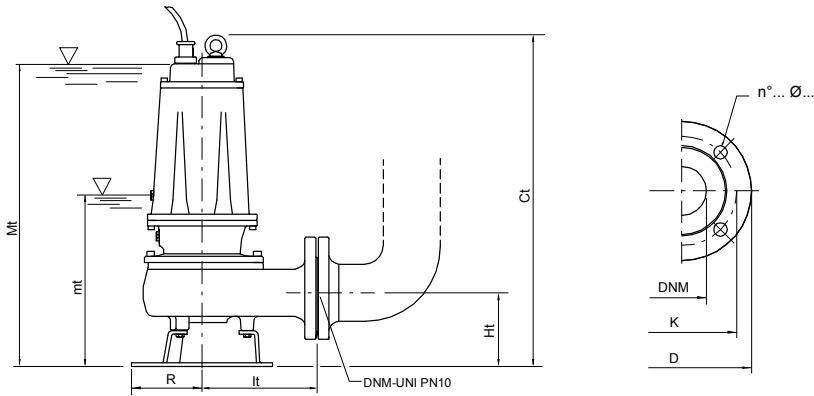

mt: minimum working level
Mt: minimum submersion level for continuous duty

TYPE	DIMENSIONS (mm)								Kg
	Ct	Ht	R	lt	mt	Mt	DNM		
DVT 160	551	123	117	191	243	513	65	39,5	
DV 160-DVT 210	551	123	117	191	243	513	65	40,5	
DV 210-DVT 310	551	123	117	191	243	513	65	41,5	
DVT 400	645	148	160	210	285	600	80	68	
DVT 550	645	148	160	210	285	600	80	71	
DVT 750	725	178	180	232	358	670	80	90	
DVT 1000	725	178	180	232	358	670	80	92,5	

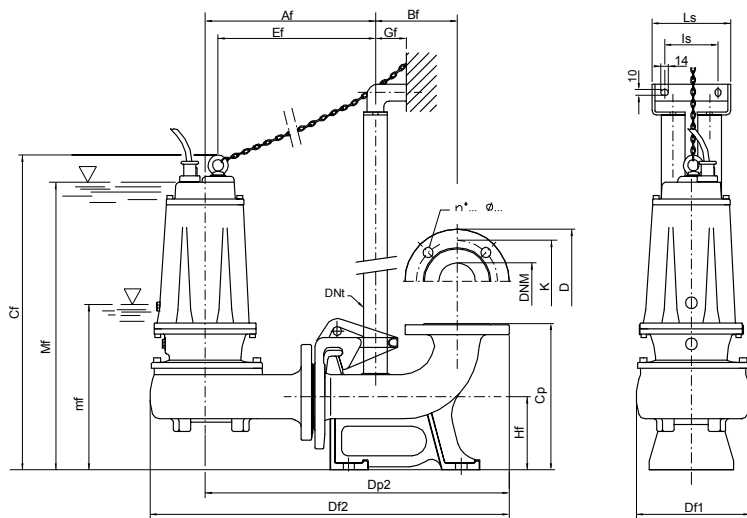

mf: minimum working level
Mf: minimum submersion level for continuous duty

Flange UNI PN 10 (mm)			
DNM	K	D	n°... Ø...
65	145	185	4... 18...
80	160	200	8... 18...

TYPE	DIMENSIONS (mm)																		
	Af	Bf	Cf	Cp	Df1	Df2	Dp2	DNt	Ef	Gf	Hf	l1	l2	ls	Ls	mf	Mf	DNM	
DVT 160 /P	303	145	559	260	200	639	541	1" 1/4	280	55	130	200	100	95	140	251	521	65	
DV 160-DVT 210/P	303	145	559	260	200	639	541	1" 1/4	280	55	130	200	100	95	140	251	521	65	
DV 210-DVT 310/P	303	145	559	260	200	639	541	1" 1/4	280	55	130	200	100	95	140	251	521	65	
DVT 400/P	350	165	690	340	220	720	615	2"	319	85	190	250	140	130	180	327	642	80	
DVT 550/P	350	165	690	340	220	720	615	2"	319	85	190	250	140	130	180	327	642	80	
DVT 750/P	370	165	745	340	235	750	638	2"	338	85	190	250	140	130	180	380	690	80	
DVT 1000/P	370	165	745	340	235	750	638	2"	338	85	190	250	140	130	180	380	690	80	

TYPE	PROTECTION		1 PUMP CONTROL PANEL			2 PUMPS CONTROL PANEL		
	1 x 230 V	3 x 400 V	1 x 230 V	3 x 400 V	400 / 690 V	1 x 230 V	3 x 400 V	400 / 690 V
DV 160	PMC 15/35-15	PT 20-30-40/4.3-6.8	EQSM + 35µF	EQSMT 10		EQ2SM + 35µF	EQ2SMT 10	
DV 210	PMC 20/50-18	PT 20-30-40/4.3-6.8	EQSM + 50µF	EQSMT 10		EQ2SM + 50µF	EQ2SMT 10	
DVT 310		PT 40-50/5.7-9.1		EQSMT 10			EQ2SMT 10	
DVT 400		PT 55-75/8.6-13.5		EQSMT 10			EQ2SMT 10	
DVT 550		PT 55-75/8.6-13.5		EQSMT 10			EQ2SMT 10	
DVT 750		PT 100/12.5-16.5		EQSMT 10	QST 7		EQ2SMT 10	Q2ST 7
DVT 1000		PT 125-150/16-21		EQSMT 10	QST 10		EQ2SMT 10	Q2ST 10

