

# ULTRA SV/SL/SLX

## Multistage Vertical

Stainless steel multistage vertical pumps. Pumping of clean non-loaded fluids, pressurizing system, irrigation, drinking and glycol water, water treatment, food industry, heating and air conditioning, washing system.

### Construction features

<b>Pump body</b>	cast iron (SV/SL); stainless steel AISI 304 (SLX)
<b>Motor bracket</b>	cast iron
<b>Impellers, diffusers, shell, motor shaft</b>	stainless steel AISI 304
<b>Mechanical seal</b>	ceramic-graphite-EPDM graphite-silicon carbide-EPDM
<b>Intermediate shaft guiding stage bush</b>	ceramic-tungsten carbide
<b>Ambient temperature</b>	max 40 °C
<b>Liquid temperature</b>	+5 ÷ 90 °C (SV) -15 ÷ 110 °C (SL/SLX)
<b>Max operating pressure</b>	8 bar ≤ 4 impellers; 14 bar ≥ 5 impellers
<b>Pump body gasket</b>	EPDM

### Motor

	3~ 220/380V - 60Hz
<b>2 pole induction motor</b>	1~ 220V - 60Hz (with thermal protection up to 1,85 kW)
<b>Insulation class</b>	F
<b>Protection degree</b>	IPX4 IPX5 ≥ 4,5 HP



**U 3 S V/ X - 120/4 T**

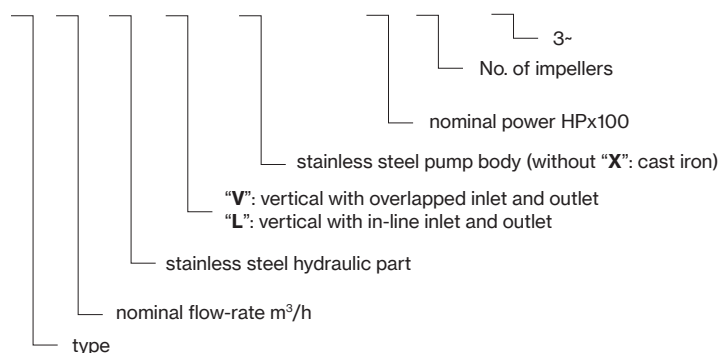

ULTRA SV



ULTRA 3-5-7 SL



ULTRA 9-18 SL



ULTRA SLX



# ULTRA SV/SL/SLX

TYPE		P2		P1 (kW)		AMPERE		Q (m³/h - l/min)								
1~	3~					1~	3~	0	0,6	1,2	1,8	2,4	3	3,6	4,2	4,8
								0	10	20	30	40	50	60	70	80
		HP	kW	1~	3~	1x220 V 60 Hz	3x380 V 60 Hz	H (m)								
U 3...120/4	U 3...120/4T	1,2	0,9	1,3	1,3	6,2	2,6	64,6	62,9	60,3	56,9	52,7	48,6	43,2	38,4	31,9
U 3...150/5	U 3...150/5T	1,75	1,29	1,6	1,6	7,7	3,4	76,9	74,8	71,5	67,8	63,4	58,8	52,8	46,5	38,8
U 3...200/6	U 3...200/6T	1,75	1,29	2,0	1,9	9,2	3,8	93,6	91,3	87,5	83,2	77,7	72,1	64,5	57,1	48,7
U 3...250/7	U 3...250/7T	2,5	1,84	2,3	2,1	10,8	4,1	109,9	107,0	102,7	97,6	90,9	84,1	75,0	66,5	56,8
U 3...300/8	U 3...300/8T	3	2,2	2,7	2,5	13,5	4,9	123,4	120,3	115,0	109,0	101,7	93,7	83,8	73,8	62,9

TYPE		P2		P1 (kW)		AMPERE		Q (m³/h - l/min)									
1~	3~					1~	3~	0	1,8	2,4	3,6	4,2	4,8	6	7,2	8,4	9
								0	30	40	60	70	80	100	120	140	150
		HP	kW	1~	3~	1x220 V 60 Hz	3x380 V 60 Hz	H (m)									
U 5...140/8	U 5...140/8T	1,75	1,29	1,9	1,8	8,9	3,6	64,3	61,1	60,0	57,0	55,5	53,1	48,3	42,4	34,2	28,6
U 5...250/5	U 5...250/5T	2,5	1,84	2,4	2,2	11,1	4,3	80,2	76,4	74,9	71,2	70,2	66,5	60,5	52,4	41,9	35,7
U 5...300/6	U 5...300/6T	3	2,2	2,9	2,6	14,5	5,1	96,6	92,1	89,7	85,7	83,1	79,8	72,7	63,6	51,0	42,8
-	U 5...350/7T	3,5	2,57	-	3,1	-	5,9	113,6	109,1	106,7	101,6	99,2	94,7	86,3	75,1	60,2	51,4
-	U 5...400/8T	4	3	-	3,5	-	6,8	129,6	124,6	122,3	116,6	113,7	109,1	99,8	87,9	69,9	60,1

TYPE		P2		P1 (kW)		AMPERE		Q (m³/h - l/min)									
1~	3~					1~	3~	0	3,6	4,2	4,8	6	7,2	8,4	9	9,6	10,8
								0	60	70	80	100	120	140	150	160	180
		HP	kW	1~	3~	1x220 V 60 Hz	3x380 V 60 Hz	H (m)									
U 7...300/4	U 7...300/4T	3	2,2	3,0	2,8	15,1	5,3	67,3	66,1	65,4	64,4	61,7	58,3	54,2	51,7	48,7	41,2
-	U 7...400/5T	4	3	-	3,5	-	6,8	85,1	84,3	83,2	82,3	79,1	75,2	69,9	66,6	62,9	54,3
-	U 7...450/6T	4,5	3,37	-	4,3	-	7,9	102,7	102,2	101,2	99,8	96,1	91,7	85,6	81,9	77,6	69,0
-	U 7...550/7T	5,5	4	-	5,1	-	9,5	120,7	119,6	118,5	116,9	112,7	107,2	99,8	95,2	90,2	82,0
-	U 7...750/8T	7,5	5,5	-	5,9	-	11,2	138,2	138,5	137,3	135,6	131,1	125,2	117,5	112,5	106,8	96,0

TYPE		P2		P1 (kW)		AMPERE		Q (m³/h - l/min)									
1~	3~					1~	3~	0	4,2	6	8,4	9,6	11,4	12	13,2	14,4	15,6
								0	70	100	140	160	190	200	220	240	260
		HP	kW	1~	3~	1x220 V 60 Hz	3x380 V 60 Hz	H (m)									
U 9...350/4	U 9...350/4T	3,5	2,57	3,3	3,2	16,1	6,0	66,5	62,6	60,7	56,7	54,3	49,7	47,9	43,5	37,8	31,5
-	U 9...400/5T	4	3	-	3,8	-	7,2	83,6	78,9	76,4	71,3	68,2	62,5	60,0	54,1	47,0	39,1
-	U 9...450/6T	4,5	3,37	-	4,6	-	8,5	100,6	94,8	92,0	85,4	81,8	74,4	71,2	64,4	55,9	45,3
-	U 9...550/7T	6	4,4	-	5,4	-	9,9	118,0	111,6	108,3	101,2	97,2	89,0	85,5	76,9	66,8	55,6
-	U 9...750/8T	7,5	5,5	-	6,3	-	11,7	135,5	128,9	125,4	116,9	112,1	102,5	98,3	87,9	75,9	62,9

TYPE		P2		P1 (kW)		A	Q (m³/h - l/min)								
3~						3~	0	7,2	9,6	12	14,4	16,8	20,4	22,8	25,2
							0	120	160	200	240	280	340	380	420
		HP	kW	3~	3x380 V 60 Hz	H (m)									
U 18...400/3T		4,5	3,37	4,0	7,4	50,2	47,8	46,1	44,1	42,0	39,6	35,9	32,6	28,1	
U 18...550/4T		6	4,4	5,5	10,1	67,2	64,6	62,6	60,1	57,4	54,5	49,9	45,9	40,2	
U 18...750/5T		7,5	5,5	6,8	12,6	84,4	81,3	79,0	76,1	73,0	69,5	63,7	58,9	52,3	
U 18...900/6T		10	7,5	8,2	15,2	101,9	98,4	95,6	92,1	88,5	84,1	77,2	71,9	63,7	



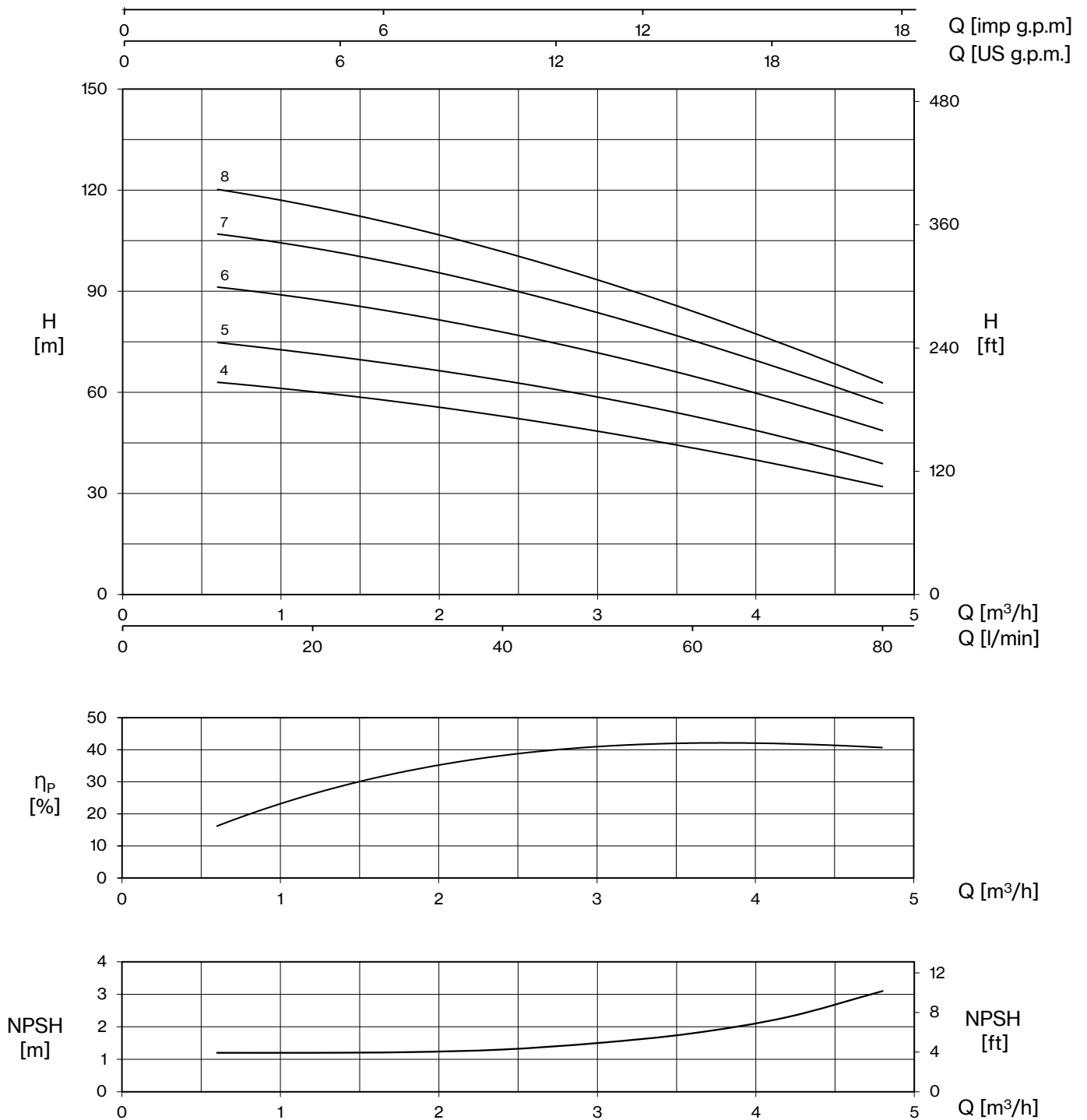

# ULTRA 5 SV/SL/SLX

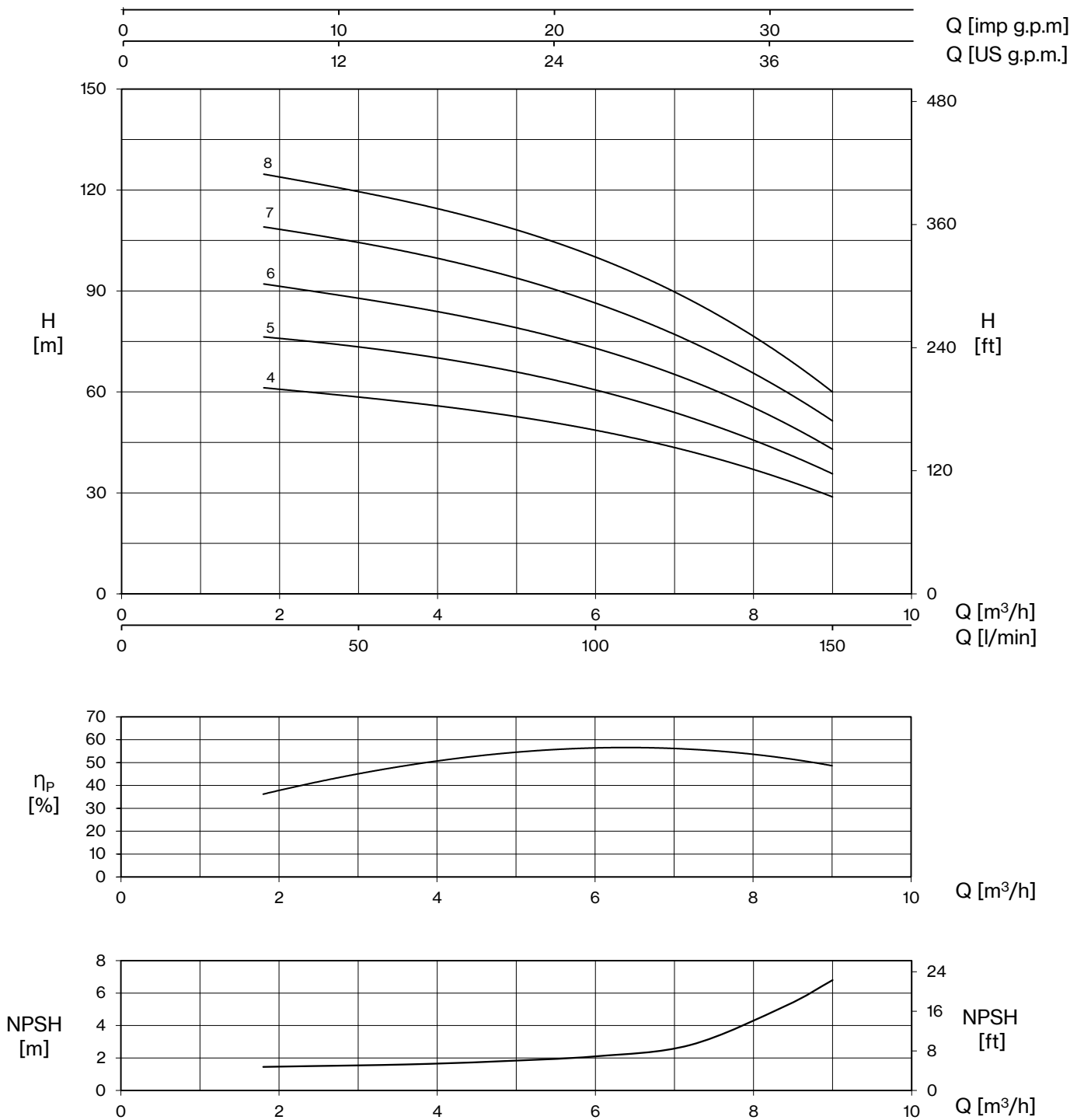

# ULTRA 7 SV/SL/SLX

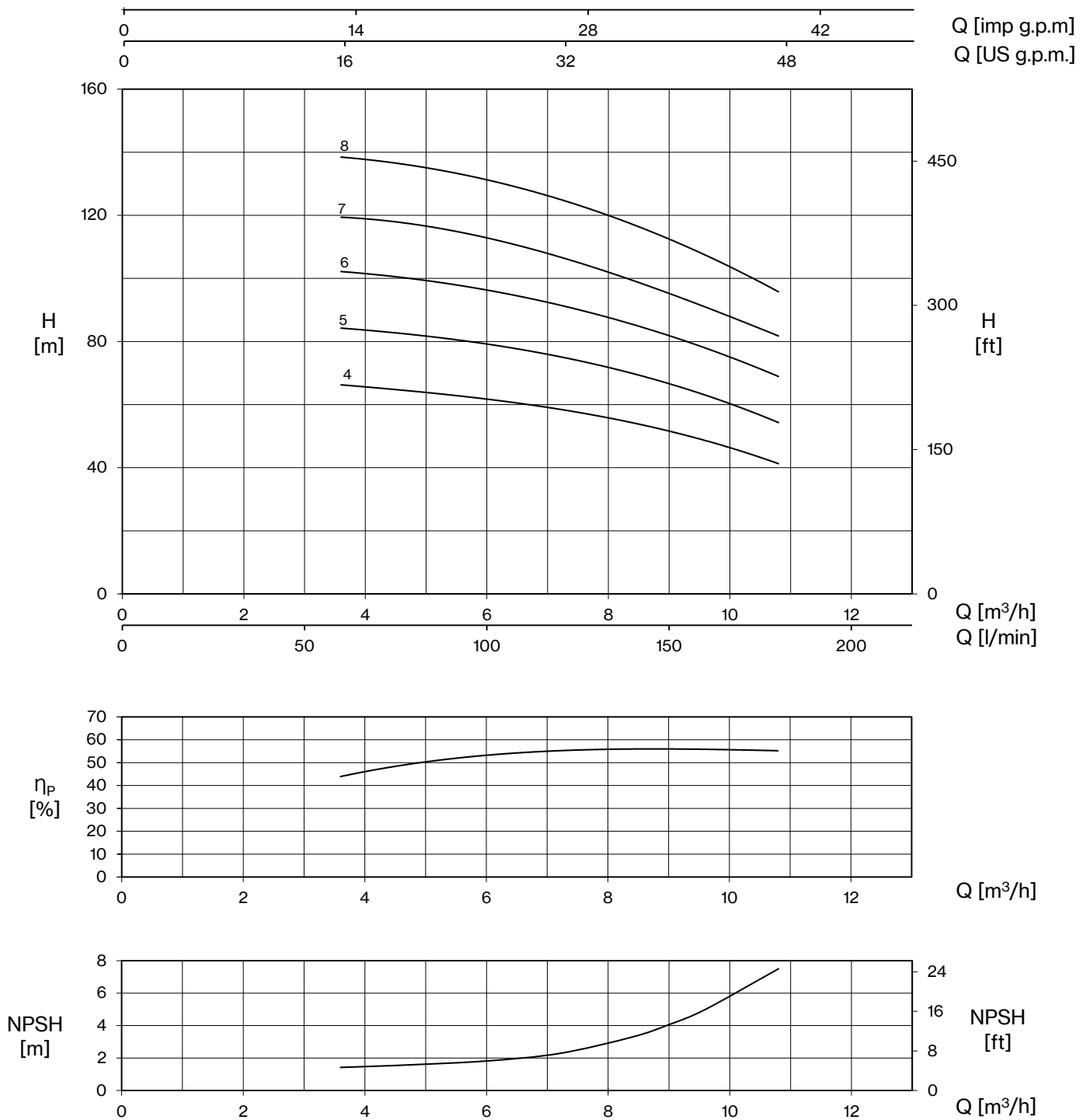

# ULTRA 9 SV/SL/SLX

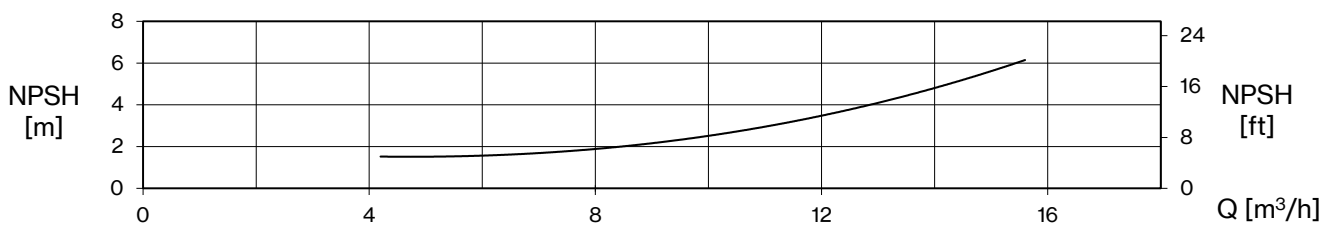
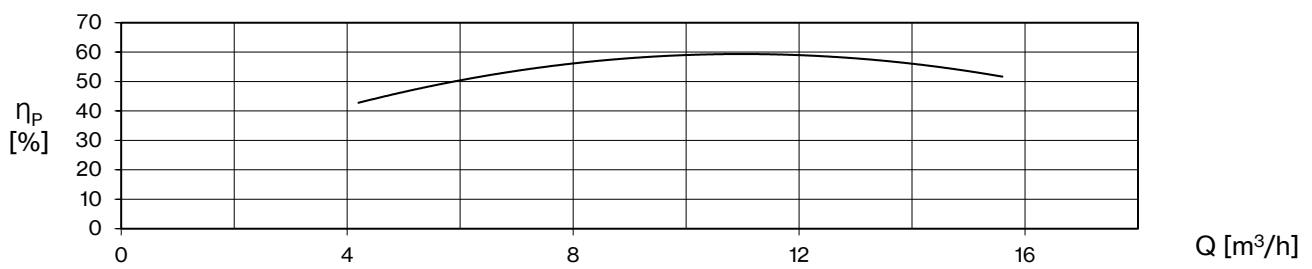
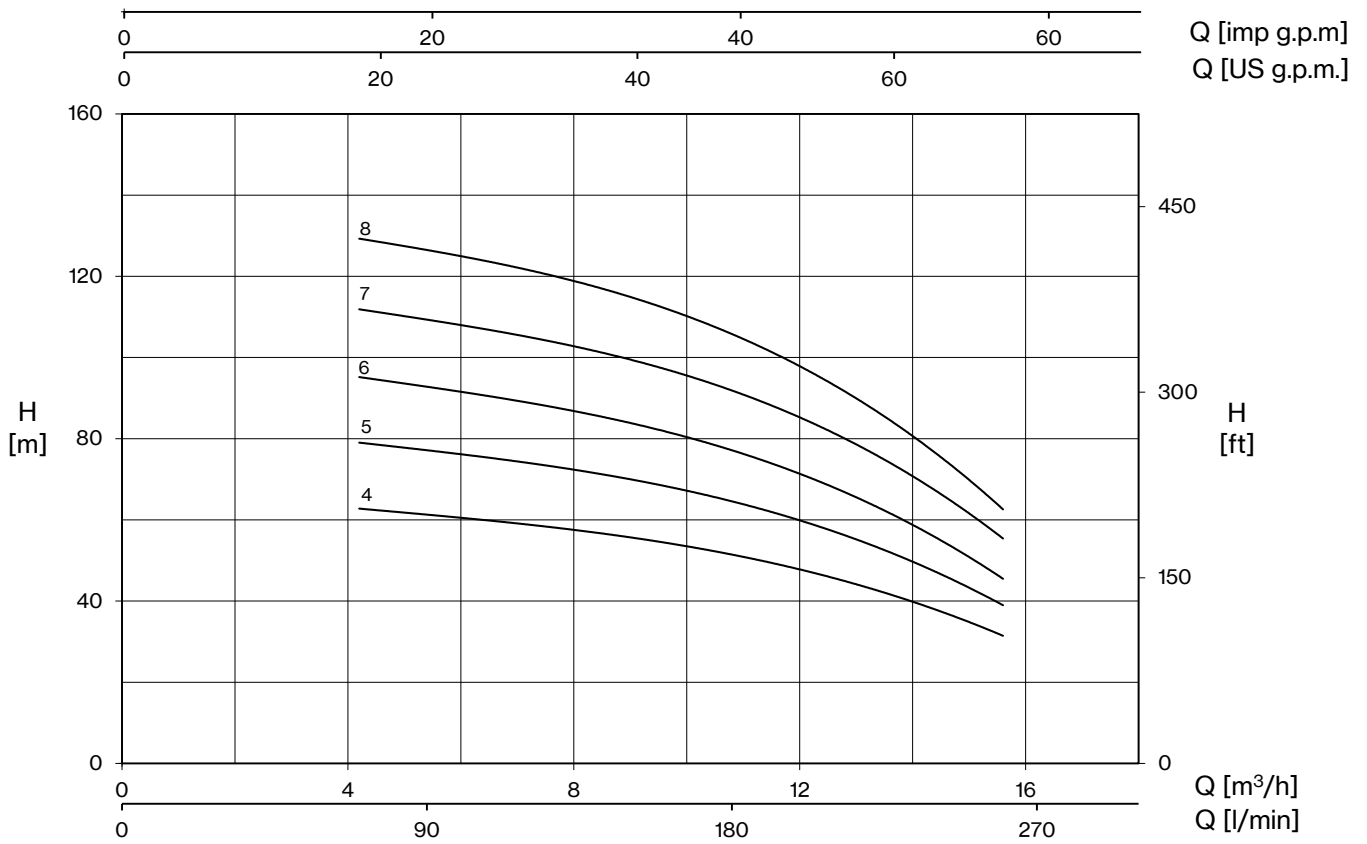

# ULTRA 18 SV/SL/SLX

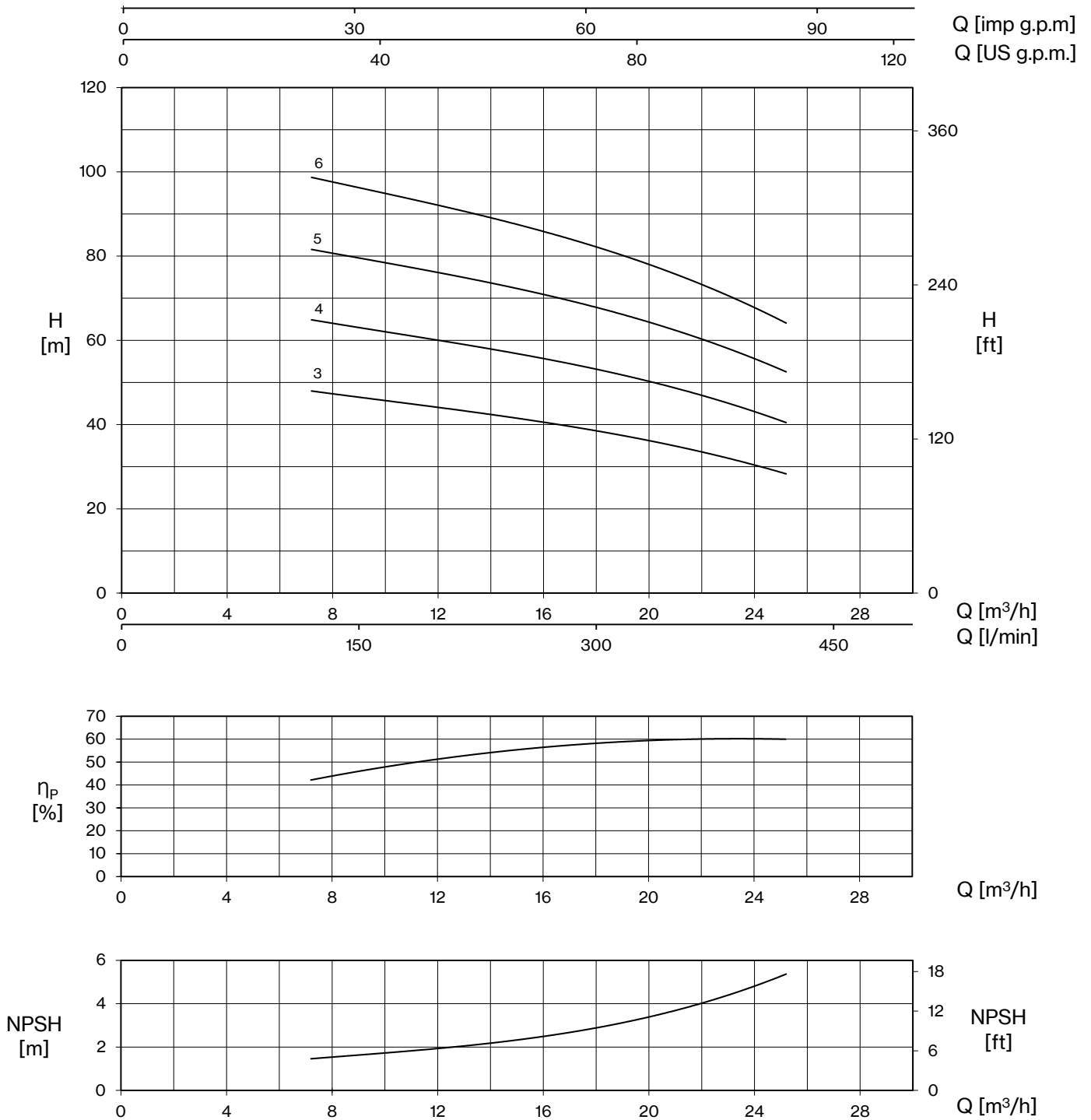

# ULTRA SV

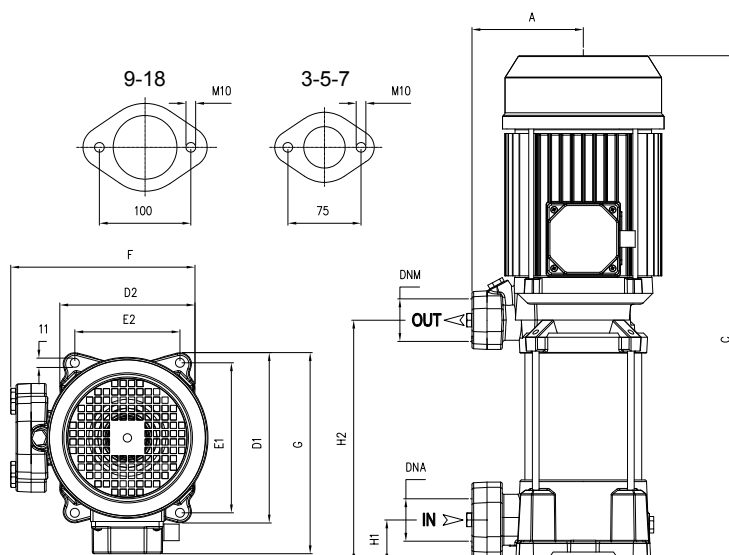

ULTRA SV	DIMENSIONS (mm)											Kg	
	A	C	D1	D2	E1	E2	F	G	H1	H2	DNA		
U 3SV-120/4	135	389	204	162	178,5	125	229	213	40	178			18,5
U 3SV-150/5	135	473	204	162	178,5	125	229	213	40	202			21,5
U 3SV-200/6	135	497	204	162	178,5	125	229	220	40	226	1" ¼ G	1" ¼ G	23,5   T 22,5
U 3SV-250/7	135	521	204	162	178,5	125	229	220	40	250			24,5   T 24
U 3SV-300/8	135	555	204	162	178,5	125	229	220	40	274			27   T 25,5
U 5SV-180/4	135	449	204	162	178,5	125	229	220	40	178			21,5   T 21
U 5SV-250/5	135	473	204	162	178,5	125	229	220	40	202			23
U 5SV-300/6	135	M 552 T 497	204	162	178,5	125	229	M 228 T 220	40	226	1" ¼ G	1" ¼ G	26   T 24
U 5SV-350/7	135	576	204	162	178,5	125	229	228	40	250			28
U 5SV-400/8	135	600	204	162	178,5	125	229	228	40	274			33,5
U 7SV-300/4	135	M 504 T 449	204	162	178,5	125	229	M 228 T 220	40	178			25   T 23
U 7SV-400/5	135	528	204	162	178,5	125	229	228	40	202			28
U 7SV-450/6	135	580	204	162	178,5	125	229	243	40	226	1" ¼ G	1" ¼ G	36,5
U 7SV-550/7	135	604	204	162	178,5	125	229	243	40	250			41
U 7SV-750/8	135	691	204	162	178,5	125	229	253	40	274			46
U 9SV-350/4	135	528	204	162	178,5	125	229	228	40	202			28   T 25,5
U 9SV-400/5	135	558	204	162	178,5	125	229	228	40	232			32
U 9SV-450/6	135	616	204	162	178,5	125	229	243	40	262	1" ½ G	1" ¼ G	33,5
U 9SV-550/7	135	646	204	162	178,5	125	229	243	40	292			36,5
U 9SV-750/8	135	739	204	162	178,5	125	229	253	40	322			46,5
U 18SV-400/3	135	536	204	162	178,5	125	229	228	50	211			29
U 18SV-550/4	135	602	204	162	178,5	125	235	243	50	248	2" G	1" ½ G	41,5
U 18SV-750/5	135	703	204	162	178,5	125	255	253	50	289			51
U 18SV-900/6	135	740	204	162	178,5	125	255	253	50	326			49,5





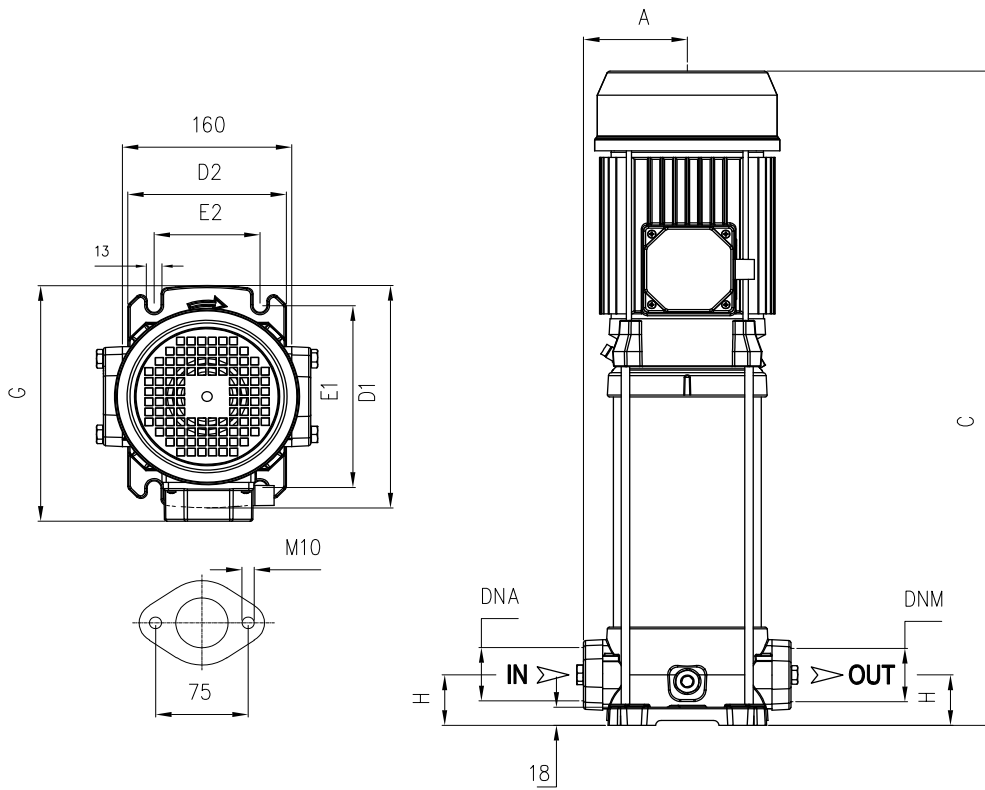

ULTRA SL/SLX	DIMENSIONS (mm)										Kg			
	A	C	D1	D2	E1	E2	G	H	DNA	DNM	SL		SLX	
	U 3SL/SLX-120/4	98	405	220	150	180	100	228	50			20		19
U 3SL/SLX-150/5	98	489	220	150	180	100	228	50			23,5		22	
U 3SL/SLX-200/6	98	513	220	150	180	100	228	50	1" ¼ G	1" ¼ G	26	T 25	24,5	T 24
U 3SL/SLX-250/7	98	537	220	150	180	100	228	50			26,5		25,5	T 25
U 3SL/SLX-300/8	98	571	220	150	180	100	228	50			29,5	T 27,5	28,5	T 26,5
U 5SL/SLX-180/4	98	465	220	150	180	100	228	50			23,5	T 23	22,5	T 21,5
U 5SL/SLX-250/5	98	489	220	150	180	100	228	50			25		24	T 23,5
U 5SL/SLX-300/6	98	568 T 513	220	150	180	100	236 T 228	50	1" ¼ G	1" ¼ G	28,5	T 26	27	T 25
U 5SL/SLX-350/7	98	592	220	150	180	100	236	50			30,5		29,5	
U 5SL/SLX-400/8	98	616	220	150	180	100	236	50			36		34,5	
U 7SL/SLX-300/4	98	M 520 T 465	220	150	180	100	M 236 T 228	50			27	T 25	26	T 24
U 7SL/SLX-400/5	98	544	220	150	180	100	236	50			30,5		29,5	
U 7SL/SLX-450/6	98	596	220	150	180	100	251	50	1" ¼ G	1" ¼ G	38,5		37,5	
U 7SL/SLX-550/7	98	620	220	150	180	100	251	50			43		42	
U 7SL/SLX-750/8	98	707	220	150	180	100	260	50			47,5		46,5	

# ULTRA SL/SLX

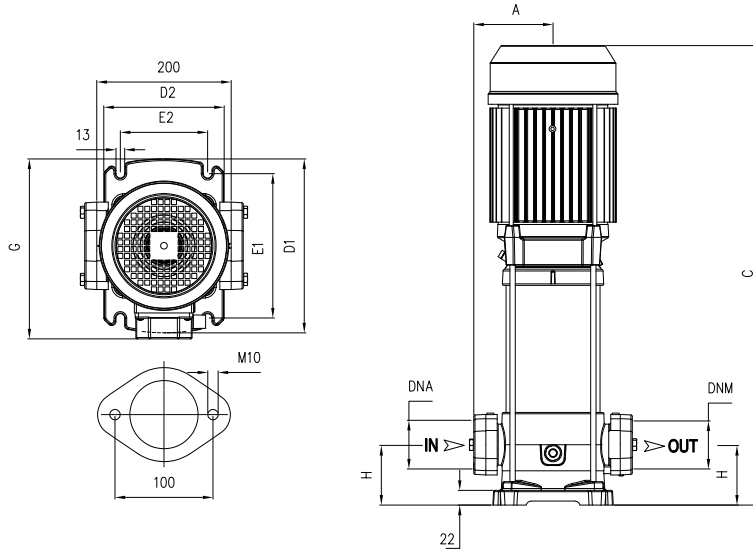

ULTRA SL/SLX	DIMENSIONS (mm)										Kg			
	A	C	D1	D2	E1	E2	G	H	DNA	DNM	SL		SLX	
	U 9SL/SLX-350/4	118	575	260	180	215	130	256	80	1" 1/2 G	1" 1/2 G	34,5	T 32	33
U 9SL/SLX-400/5 T	118	605	260	180	215	130	256	80	39			37		
U 9SL/SLX-450/6 T	118	663	260	180	215	130	271	80	48			37,5		
U 9SL/SLX-550/7 T	118	693	260	180	215	130	271	80	47,5			46		
U 9SL/SLX-750/8 T	118	786	260	180	215	130	280	80	52			50,5		
U 18SL/SLX-400/3 T	118	577	260	180	215	130	256	90	2" G	2" G	34,5	33,5	34,5	33,5
U 18SL/SLX-550/4 T	118	643	260	180	215	130	271	90			47	45,5	47	45,5
U 18SL/SLX-750/5 T	118	743	260	180	215	130	280	90			56	54,5	56	54,5
U 18SL/SLX-900/6 T	118	781	260	180	215	130	280	90			55	53,5	55	53,5

1- 110V - 60Hz	
TYPE	I (A)
U 3...-120/4	12,4

MODEL	TRUCK		CONTAINER	
	PALLET (cm)	N° pumps	PALLET (cm)	N° pumps
U 3SV-120/4-150/5	80×120×150	42	80×120×175	49
U 3SV-200/6-300/8 T	80×120×150	42	80×120×175	49
U 3SV-200/6 -300/8	80×120×155	30	80×120×180	35
U 5SV-180/4-350/7	80×120×150	42	80×120×175	49
U 5SV-400/8 T	80×120×155	30	80×120×180	35
U 7SV-300/4-400/5 T	80×120×150	42	80×120×175	49
U 7SV-450/6 T-550/7 T	85×110×125	20	85×110×150	24
U 7SV-750/8 T	85×110×150	20	85×110×150	20
U 9SV-350/4	80×120×150	42	80×120×175	49
U 9SV-400/5	80×120×155	30	80×120×180	35
U 9SV-450/6 T-550/7 T	85×110×125	20	85×110×150	24
U 9SV-750/8 T	85×110×150	20	85×110×150	20
U 18SV-400/3 T-550/4 T	80×120×150	42	80×120×175	49
U 18SV-750/5 T-900/6 T	85×110×125	20	85×110×150	24

MODEL	TRUCK		CONTAINER	
	PALLET (cm)	N° pumps	PALLET (cm)	N° pumps
U 3SL/SLX-120/4-150/5	85×110×150	36	85×110×170	42
U 3SL/SLX-200/6-300/8	80×120×150	30	80×120×170	35
U 5SL/SLX-180/4-250/5-300/6 T	85×110×150	36	85×110×170	42
U 5SL/SLX-300/6-350/7 T	80×120×150	30	80×120×170	35
U 5SL/SLX-400/8 T	85×110×150	20	85×110×150	20
U 7SL/SLX-300/4 T	85×110×150	36	85×110×170	42
U 7SL/SLX-300/4 -400/5 T	80×120×150	30	80×120×170	35
U 7SL/SLX-450/6 T-550/7 T	80×120×150	30	80×120×170	35
U 7SL/SLX-750/8 T	85×110×150	20	85×110×150	20
U 9SL/SLX-350/4-400/5 T	80×120×155	25	80×120×185	30
U 9SL/SLX-450/6 T-550/7 T	85×110×150	20	85×110×150	20
U 9SL/SLX-750/8 T	85×110×150	20	85×110×150	20
U 18SL/SLX-400/3 T-550/4 T	80×120×155	25	80×120×185	30
U 18SL/SLX-750/5 T-900/6 T	85×110×150	20	85×110×150	20



# ULTRA V-SV-L-SL-LG-SLG Serie-Mechanical seal and bearings

MECHANICAL SEAL	PUMP MODEL	SHAFT Ø		STANDARD MATERIAL	OPTIONAL
	U3-120/4, U5-180/4, U7-300/4, U9-350/4, U18-400/3, U18-550/4	14mm / S	<b>Rotating face</b> <b>Stationary face</b> <b>Elastomer</b>	Graphite Ceramic EPDM	SiC SiC EPDM
	U3-150/5, U3-200/6, U3-250/7, U3-300/8, U5-250/5, U5-300/6, U5-350/7, U5-400/8, U7-400/5, U7-450/6, U7-550/7, U9-400/5, U9-450/6, U9-550/7, U9-750/8	14mm	<b>Rotating face</b> <b>Stationary face</b> <b>Elastomer</b>	Graphite SiC EPDM	SiC SiC EPDM
	U18-750/5, U18-900/6, U18-950/7, U18-1000/8	14mm / L	<b>Rotating face</b> <b>Stationary face</b> <b>Elastomer</b>	Graphite Ceramic EPDM	SiC SiC EPDM
	U3-350/10, U3-400/12, U3-450/14, U3-550/16, U5-450/10, U5-550/12, U5-750/14, U7-800/10, U7-900/12, U7-1000/14, U9-800/10, U9-900/12, U9-1000/14	14mm / Balanced seal	<b>Rotating face</b> <b>Stationary face</b> <b>Elastomer</b>	Tungsten carbide Graphite EPDM	- - -

BEARINGS	PUMP MODEL	TYPE	
	U3-120/4	6202-ZZ	6302-ZZ C3
	U3-150/5, U3-200/6, U3-250/7, 3- U3-300/8, U 5-180/4, U5-250/5, 3- U5-300/6, 3- U7-300/4	6204-ZZ	6304-ZZ C3
	1- U3-300/8, U3-350/10, U3-400/12, 1- U5-300/6, U5-350/7, U5-400/8, 1- U7-300/4, U7-400/5, U9-350/4, U9-400/5, U18-400/3	6203-ZZ	6305-ZZ C3
	U7-450/6, U7-550/7, U9-450/6, U9-550/7, U18-550/4	6204-ZZ	6306-ZZ-C3
	U3-450/14, U3-550/16, U5-450/10	6204-ZZ	3206-ZZ C3
	U5-550/12, U5-750/14, U7-750/8, U7-800/10, U7-900/12, U9-750/8, U9-800/10, U9-900/12, U18-750/5, U18-900/6	6206-ZZ C3	3306-ZZ C3
	U7-1000/14, U9-1000/14, U18-950/7, U18-1000/8	6206-ZZ C3	3308-ZZ C3



# ULTRA+VSD

Vertical booster pump with variable speed



## DESCRIPTION

Horizontal pump of ULTRA series provided with variable speed drive EPIC or IPFC. This booster pump assure the desired pressure regardless changes on flow demand making it suitable for low or missing pressure in residential systems and industrial applications. It is required the installation of a membrane tank downstream the system.

## FEATURES

- EPIC or IPFC variable speed drive
- Vertical pump of ULTRA series
- Pressure sensor
- Cable with plug

## FUNCTIONING

If the pressure in the network drops the pump will starts and gradually speeds up to provide with the set pressure. When the water demand decreases, the pressure will rise causing the pump speed to slow down and eventually to stop the pump if demand ceases. The pump will remain on standby waiting to start at the next water demand.

## SELECTION

The table below shows the vertical ULTRA pump models available for the assembly with EPIC or IPFC. Consult the catalog at the ULTRA series for pump specifics and characteristic curves.

# ULTRA+VSD

PUMP								VSD		
TYPE	MODEL	Version						TYPE	Power system	
		V	SV	L	SL/SLX	LG	SLG/SLGX		in	out
U 3	120/4T	■	■	■	■	-	-	EPIC	1-220	3-220
		■	■	■	■	-	-	IPFC109	1-220	3-220
		■	■	■	■	-	-	IPFC306	3-380	3-380
		■	■	■	■	-	-	IPFC306-220	3-220	3-220
	150/5T	■	■	■	■	-	-	EPIC	1-220	3-220
		■	■	■	■	-	-	IPFC109	1-220	3-220
		■	■	■	■	-	-	IPFC306	3-380	3-380
		■	■	■	■	-	-	IPFC309-220	3-220	3-220
	200/6T	■	■	■	■	-	-	EPIC	1-220	3-220
		■	■	■	■	-	-	IPFC114	1-220	3-220
		■	■	■	■	-	-	IPFC306	3-380	3-380
		■	■	■	■	-	-	IPFC309-220	3-220	3-220
	250/7T	■	■	■	■	-	-	EPIC	1-220	3-220
		■	■	■	■	-	-	IPFC114	1-220	3-220
		■	■	■	■	-	-	IPFC306	3-380	3-380
		■	■	■	■	-	-	IPFC309-220	3-220	3-220
300/8T	■	■	■	■	-	-	IPFC114	1-220	3-220	
	■	■	■	■	-	-	IPFC306	3-380	3-380	
	■	■	■	■	-	-	IPFC314-220	3-220	3-220	
	■	■	■	■	-	-	IPFC309	3-380	3-380	
350/10T	-	-	-	-	-	■	IPFC314-220	3-220	3-220	
	-	-	-	-	-	■	IPFC309	3-380	3-380	
400/12T	-	-	-	-	-	■	IPFC314-220	3-220	3-220	
	-	-	-	-	-	■	IPFC309	3-380	3-380	
450/14T	-	-	-	-	-	■	IPFC311	3-380	3-380	
	-	-	-	-	-	■	IPFC318-220	3-220	3-220	
U 5	180/4T	■	■	■	■	-	-	EPIC	1-220	3-220
		■	■	■	■	-	-	IPFC109	1-220	3-220
		■	■	■	■	-	-	IPFC306	3-380	3-380
		■	■	■	■	-	-	IPFC309-220	3-220	3-220
	250/5T	■	■	■	■	-	-	EPIC	1-220	3-220
		■	■	■	■	-	-	IPFC114	1-220	3-220
		■	■	■	■	-	-	IPFC306	3-380	3-380
		■	■	■	■	-	-	IPFC309-220	3-220	3-220
	300/6T	■	■	■	■	-	-	IPFC114	1-220	3-220
		■	■	■	■	-	-	IPFC306	3-380	3-380
		■	■	■	■	-	-	IPFC314-220	3-220	3-220
		■	■	■	■	-	-	IPFC309	3-380	3-380
350/7T	■	■	■	■	-	-	IPFC314-220	3-220	3-220	
	■	■	■	■	-	-	IPFC309	3-380	3-380	
400/8T	■	■	■	■	-	-	IPFC309	3-380	3-380	
	■	■	■	■	-	-	IPFC314-220	3-220	3-220	
450/10T	-	-	-	-	-	■	IPFC311	3-380	3-380	
	-	-	-	-	-	■	IPFC318-220	3-220	3-220	
550/12T	-	-	-	-	-	■	IPFC314	3-380	3-380	
	-	-	-	-	-	■	IPFC325-220	3-220	3-220	
750/14T	-	-	-	-	-	■	IPFC314	3-380	3-380	
	-	-	-	-	-	■	IPFC325-220	3-220	3-220	



PUMP								VSD		
TYPE	MODEL	Version						TYPE	Power system	
		V	SV	L	SL/SLX	LG	SLG/SLGX		in	out
U 7	300/4T	■	■	■	■	-	-	IPFC114	1-220	3-220
		■	■	■	■	-	-	IPFC306	3-380	3-380
		■	■	■	■	-	-	IPFC314-220	3-220	3-220
	400/5T	■	■	■	■	-	-	IPFC309	3-380	3-380
		■	■	■	■	-	-	IPFC314-220	3-220	3-220
	450/6T	■	■	■	■	-	-	IPFC309	3-380	3-380
		■	■	■	■	-	-	IPFC318-220	3-220	3-220
	550/7T	■	■	■	■	-	-	IPFC311	3-380	3-380
		■	■	■	■	-	-	IPFC318-220	3-220	3-220
	750/8T	■	■	■	■	-	-	IPFC314	3-380	3-380
		■	■	■	■	-	-	IPFC325-220	3-220	3-220
	800/10T	-	-	-	-	-	■	IPFC318	3-380	3-380
		-	-	-	-	-	■	IPFC330-220	3-220	3-220
	900/12T	-	-	-	-	-	■	IPFC318	3-380	3-380
-		-	-	-	-	■	IPFC330-220	3-220	3-220	
U 9	350/4T	■	■	■	■	-	-	IPFC309	3-380	3-380
		■	■	■	■	-	-	IPFC314-220	3-220	3-220
	400/5T	■	■	■	■	-	-	IPFC309	3-380	3-380
		■	■	■	■	-	-	IPFC314-220	3-220	3-220
	450/6T	■	■	■	■	-	-	IPFC311	3-380	3-380
		■	■	■	■	-	-	IPFC318-220	3-220	3-220
	550/7T	■	■	■	■	-	-	IPFC311	3-380	3-380
		■	■	■	■	-	-	IPFC325-220	3-220	3-220
	750/8T	■	■	■	■	-	-	IPFC314	3-380	3-380
		■	■	■	■	-	-	IPFC325-220	3-220	3-220
800/10T	-	-	-	-	-	■	IPFC318	3-380	3-380	
	-	-	-	-	-	■	IPFC330-220	3-220	3-220	
900/12T	-	-	-	-	-	■	IPFC325	3-380	3-380	
	-	-	-	-	-	-	-	3-220	3-220	

# ULTRA+VSD

		PUMP							VSD		
TYPE	MODEL	Version							TYPE	Power system	
		V	SV	L	SL/SLX	LG	HS	HX		in	out
U 18	200/1T	-	-	-	-	-	-	■	IPFC109	1-220	3-220
		-	-	-	-	-	-	■	IPFC306	3-380	3-380
		-	-	-	-	-	-	■	IPFC306-220	3-220	3-220
	400/2T	-	-	-	-	-	-	■	IPFC114	1-220	3-220
		-	-	-	-	-	-	■	IPFC306	3-380	3-380
		-	-	-	-	-	-	■	IPFC314-220	3-220	3-220
	400/3T	■	■	■	■	-	-	-	IPFC309	3-380	3-380
		■	■	■	■	-	-	-	IPFC314-220	3-220	3-220
	550/3T	-	-	-	-	-	-	■	IPFC311	3-380	3-380
		-	-	-	-	-	-	■	IPFC318-220	3-220	3-220
	550/4T	■	■	■	■	-	-	-	IPFC311	3-380	3-380
		■	■	■	■	-	-	-	IPFC325-220	3-220	3-220
	750/4T	-	-	-	-	-	-	■	IPFC314	3-380	3-380
		-	-	-	-	-	-	■	IPFC325-220	3-220	3-220
	750/5T	■	■	■	■	-	-	-	IPFC314	3-380	3-380
		■	■	■	■	-	-	-	IPFC325-220	3-220	3-220
	900/6T	■	■	■	■	-	-	-	IPFC318	3-380	3-380
		■	■	■	■	-	-	-	IPFC330-220	3-220	3-220
	950/7T	-	-	-	-	■	-	-	IPFC318	3-380	3-380
		-	-	-	-	■	-	-	IPFC330-220	3-220	3-220
1000/5T	-	-	-	-	-	-	■	IPFC318	3-380	3-380	
	-	-	-	-	-	-	■	IPFC330-220	3-220	3-220	
1500/6T	-	-	-	-	-	-	■	IPFC325	3-380	3-380	
1500/7T	-	-	-	-	-	-	■	IPFC325	3-380	3-380	
1500/8T	-	-	-	-	-	-	■	IPFC330	3-380	3-380	
2000/9T	-	-	-	-	-	-	■	IPFC330	3-380	3-380	
2000/10T	-	-	-	-	-	-	■	IPFC330	3-380	3-380	
2000/11T	-	-	-	-	-	-	■	IPFC330	3-380	3-380	
U 22	300/1T	-	-	-	-	-	■	■	IPFC114	1-220	3-220
		-	-	-	-	-	■	■	IPFC306	3-380	3-380
		-	-	-	-	-	■	■	IPFC309-220	3-220	3-220
	550/2T	-	-	-	-	-	■	■	IPFC309	3-380	3-380
		-	-	-	-	-	■	■	IPFC318-220	3-220	3-220
	750/3T	-	-	-	-	-	■	■	IPFC314	3-380	3-380
		-	-	-	-	-	■	■	IPFC325-220	3-220	3-220
	1000/4T	-	-	-	-	-	■	■	IPFC318	3-380	3-380
-		-	-	-	-	■	■	IPFC330-220	3-220	3-220	
1500/5T	-	-	-	-	-	■	■	IPFC325	3-380	3-380	
1500/6T	-	-	-	-	-	■	■	IPFC325	3-380	3-380	
2000/7T	-	-	-	-	-	■	■	IPFC330	3-380	3-380	
2000/8T	-	-	-	-	-	■	■	IPFC330	3-380	3-380	
U 35	400/1-1RT	-	-	-	-	-	■	■	IPFC309	3-380	3-380
		-	-	-	-	-	■	■	IPFC314-220	3-220	3-220
	550/1T	-	-	-	-	-	■	■	IPFC311	3-380	3-380
		-	-	-	-	-	■	■	IPFC318-220	3-220	3-220
	750/2-2RT	-	-	-	-	-	■	■	IPFC314	3-380	3-380
		-	-	-	-	-	■	■	IPFC325-220	3-220	3-220
	1000/2-1RT	-	-	-	-	-	■	■	IPFC318	3-380	3-380
		-	-	-	-	-	■	■	IPFC330-220	3-220	3-220
	1500/2T	-	-	-	-	-	■	■	IPFC325	3-380	3-380
	1500/3-2RT	-	-	-	-	-	■	■	IPFC325	3-380	3-380
1500/3-1RT	-	-	-	-	-	■	■	IPFC325	3-380	3-380	
2000/3T	-	-	-	-	-	■	■	IPFC325	3-380	3-380	
2000/4-2RT	-	-	-	-	-	■	■	IPFC330	3-380	3-380	
2000/4-1RT	-	-	-	-	-	■	■	IPFC330	3-380	3-380	



PUMP									VSD		
TYPE	MODEL	Version							TYPE	Power system	
		V	SV	L	SL/SLX	LG	HS	HX		in	out
U 50	750/1-1RT	-	-	-	-	-	■	■	IPFC311	3-380	3-380
		-	-	-	-	-	■	■	IPFC325-220	3-220	3-220
	1000/1T	-	-	-	-	-	■	■	IPFC314	3-380	3-380
		-	-	-	-	-	■	■	IPFC325-220	3-220	3-220
	1500/2-2RT	-	-	-	-	-	■	■	IPFC325	3-380	3-380
	1500/2-1RT	-	-	-	-	-	■	■	IPFC325	3-380	3-380
2000/2T	-	-	-	-	-	■	■	IPFC330	3-380	3-380	
U 75	1000/1-1RT	-	-	-	-	-	■	■	IPFC314	3-380	3-380
		-	-	-	-	-	■	■	IPFC325-220	3-220	3-220
	1500/1T	-	-	-	-	-	■	■	IPFC325	3-380	3-380
	2000/2-2RT	-	-	-	-	-	■	■	IPFC330	3-380	3-380
U 90	1500/1-1RT	-	-	-	-	-	■	■	IPFC325	3-380	3-380
	2000/1RT	-	-	-	-	-	■	■	IPFC330	3-380	3-380