

# ULTRA LG

## Multistage Vertical

Stainless steel multistage vertical pumps. Pumping of clean non-loaded fluids, pressurizing system, irrigation, drinking and glycol water, water treatment, food industry, heating and air conditioning, washing system.

### Construction features

<b>Pump body</b>	cast iron
<b>Motor bracket</b>	cast iron
<b>Impellers, diffusers</b>	Noryl®
<b>Shell, motor shaft</b>	stainless steel AISI 304
<b>Mechanical seal</b>	ceramic-graphite-EPDM graphite-silicon carbide-EPDM
<b>Intermediate shaft guiding stage bush</b>	ceramic-tungsten carbide
<b>Ambient temperature</b>	max 40 °C
<b>Liquid temperature</b>	+5 ÷ +35 °C
<b>Max operating pressure</b>	14 bar
<b>Pump body gasket</b>	EPDM

### Motor

<b>2 pole induction motor</b>	3~ 220/380V - 60Hz
<b>Insulation class</b>	F
<b>Protection degree</b>	IPX5



**U18 S V/ X/ G - 950/7 T**

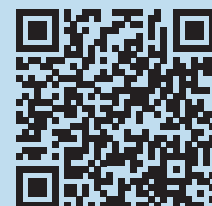
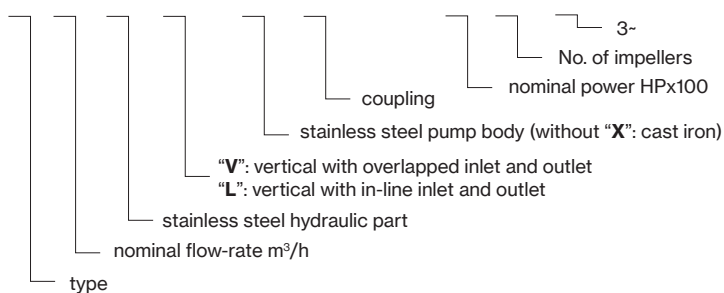

# ULTRA V/L - ULTRA LG

TYPE		P2		P1 (kW)		AMPERE		Q (m³/h - l/min)								
1~	3~					1~	3~	0	0,6	1,2	1,8	2,4	3	3,6	4,2	4,8
								0	10	20	30	40	50	60	70	80
		HP	kW	1~	3~	1x220 V 60 Hz	3x380 V 60 Hz	H (m)								
U 3...120/4	U 3...120/4T	1,2	0,9	1,5	1,4	6,9	2,8	60,5	57,6	54,3	50,5	46,6	41,9	37,7	32,7	27,8
U 3...150/5	U 3...150/5T	1,75	1,29	1,6	1,5	7,5	3,3	79,2	78,8	76,5	72,8	68,4	62,8	56,6	49,3	41,2
U 3...200/6	U 3...200/6T	2,5	1,84	1,9	1,8	8,9	3,7	95,1	95,2	91,9	87,7	82,4	75,4	68,3	59,4	50,1
U 3...250/7	U 3...250/7T	2,5	1,84	2,2	2,0	10,4	4,0	110,6	109,9	106,6	101,3	94,8	86,6	78,0	67,5	55,9
U 3...300/8	U 3...300/8T	3	2,2	2,7	2,4	13,5	4,8	126,5	125,2	122,4	116,5	109,4	100,6	90,5	78,8	65,1

TYPE		P2		P1 (kW)		AMPERE		Q (m³/h - l/min)									
1~	3~					1~	3~	0	1,8	2,4	3	3,6	4,2	4,8	6	7,2	8,4
								0	30	40	50	60	70	80	100	120	140
		HP	kW	1~	3~	1x220 V 60 Hz	3x380 V 60 Hz	H (m)									
U 5...180/4	U 5...180/4T	1,75	1,29	1,9	1,8	9,1	3,6	66,0	64,2	63,2	61,7	59,9	58,6	55,5	49,8	42,0	32,2
U 5...250/5	U 5...250/5T	2,5	1,84	2,4	2,2	11,1	4,3	82,9	80,4	79,0	77,4	74,9	72,6	69,4	61,9	52,1	40,5
U 5...300/6	U 5...300/6T	3	2,2	3,0	2,6	15,1	5,1	99,8	96,8	95,1	92,8	90,1	87,7	83,2	74,4	62,5	47,9
-	U 5...350/7T	3,5	2,57	-	3,2	-	6,0	116,5	113,7	111,6	109,1	106,3	101,9	98,6	87,7	73,7	57,3
-	U 5...400/8T	4	3	-	3,6	-	6,9	134,7	131,1	129,2	126,1	123,0	118,4	114,1	101,7	86,0	66,5

TYPE		P2		P1 (kW)		AMPERE		Q (m³/h - l/min)								
1~	3~					1~	3~	0	3,6	4,2	4,8	6	7,2	8,4	9	9,6
								0	60	70	80	100	120	140	150	160
		HP	kW	1~	3~	1x220 V 60 Hz	3x380 V 60 Hz	H (m)								
U 7...300/4	U 7...300/4T	3	2,2	2,9	2,6	14,5	5,1	71,1	68,5	67,4	65,9	62,2	57,3	51,4	48,0	44,3
-	U 7...400/5T	4	3	-	3,4	-	6,5	91,3	90,1	89,1	87,6	83,3	77,5	70,5	66,5	62,2
-	U 7...450/6T	4,5	3,37	-	4,2	-	7,7	110,1	108,5	107,2	105,3	100,2	93,5	85,5	80,9	75,9
-	U 7...550/7T	5,5	4	-	4,8	-	9,0	129,1	127,4	125,7	123,6	117,4	108,9	98,6	92,9	86,7
-	U 7...750/8T	7,5	5,5	-	5,6	-	10,8	148,2	147,2	145,8	143,6	137,3	128,8	118,5	112,8	106,6

TYPE		P2		P1 (kW)		AMPERE		Q (m³/h - l/min)									
1~	3~					1~	3~	0	4,2	6	8,4	9,6	11,4	12	13,2	14,4	15,6
								0	70	100	140	160	190	200	220	240	260
		HP	kW	1~	3~	1x220 V 60 Hz	3x380 V 60 Hz	H (m)									
U 9...350/4	U 9...350/4T	3,5	2,57	3,2	3,1	15,8	5,9	67,0	62,3	60,1	56,1	53,4	48,2	45,9	41,0	35,8	30,0
-	U 9...400/5T	4	3	-	3,7	-	7,0	83,6	77,7	74,9	70,2	66,8	59,9	57,0	50,7	44,2	36,9
-	U 9...450/6T	4,5	3,37	-	4,5	-	8,3	101,9	95,2	91,6	85,3	81,4	72,9	69,5	62,1	54,3	45,5
-	U 9...550/7T	6	4,4	-	5,3	-	9,8	120,6	114,0	110,0	102,6	97,7	88,1	84,0	74,9	65,6	55,7
-	U 9...750/8T	7,5	5,5	-	6,2	-	11,6	138,0	130,5	126,1	117,4	111,9	101,3	97,1	87,6	75,9	63,5

TYPE		P2		P1 (kW)	A	Q (m³/h - l/min)								
3~	3~				0	7,2	9,6	12	14,4	16,8	20,4	22,8	25,2	
					0	120	160	200	240	280	340	380	420	
		HP	kW	3~	3x380 V 60 Hz	H (m)								
U 18...400/3T		4,5	3,37	3,9	7,3	50,8	48,8	48,2	47,0	45,3	43,1	37,6	32,7	27,4
U 18...550/4T		6	4,4	5,2	9,7	68,3	66,3	65,7	64,3	62,2	59,4	52,3	45,9	39,2
U 18...750/5T		7,5	5,5	6,7	12,3	86,4	84,6	84,1	82,2	79,6	76,2	67,2	59,2	50,6
U 18...900/6T		10	7,5	8,0	14,9	104,0	102,2	102,0	99,8	97,0	93,1	82,6	73,0	62,6

# ULTRA LG

TYPE		P2		P1 (kW)	A	Q (m³/h - l/min)							
3~	3~				0	7,2	9,6	12	14,4	16,8	20,4	22,8	
					0	120	160	200	240	280	340	380	
		HP	kW	3~	3x380 V 60 Hz	H (m)							
U 18LG-950/7T		10	7,5	9,0	15,4	120,3	117,5	116,4	113,3	109,0	103,7	89,9	74,7



# ULTRA 18 LG

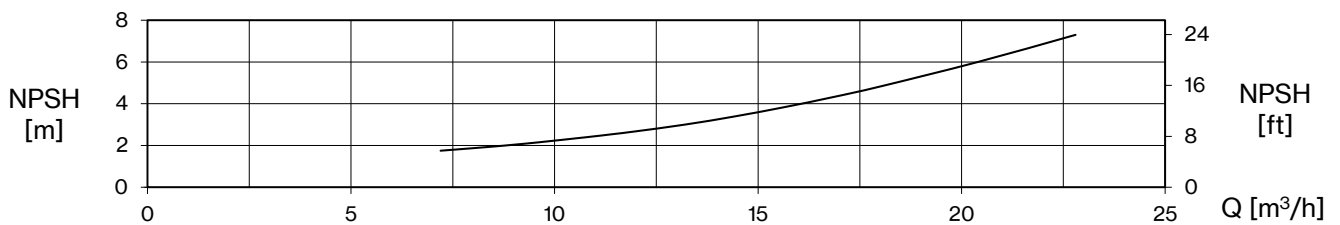
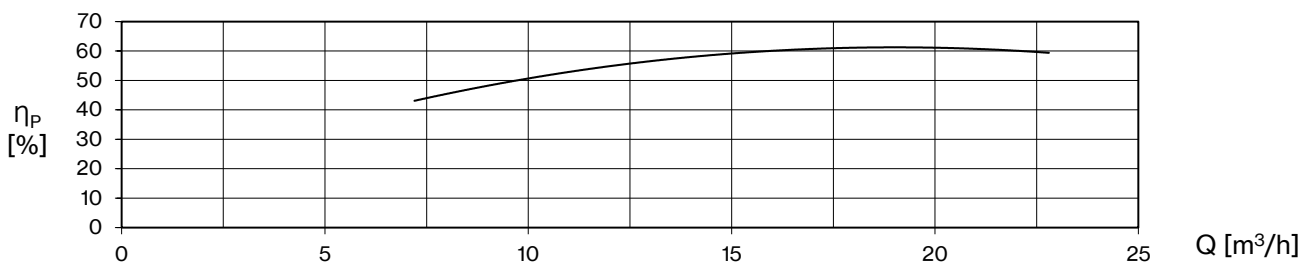
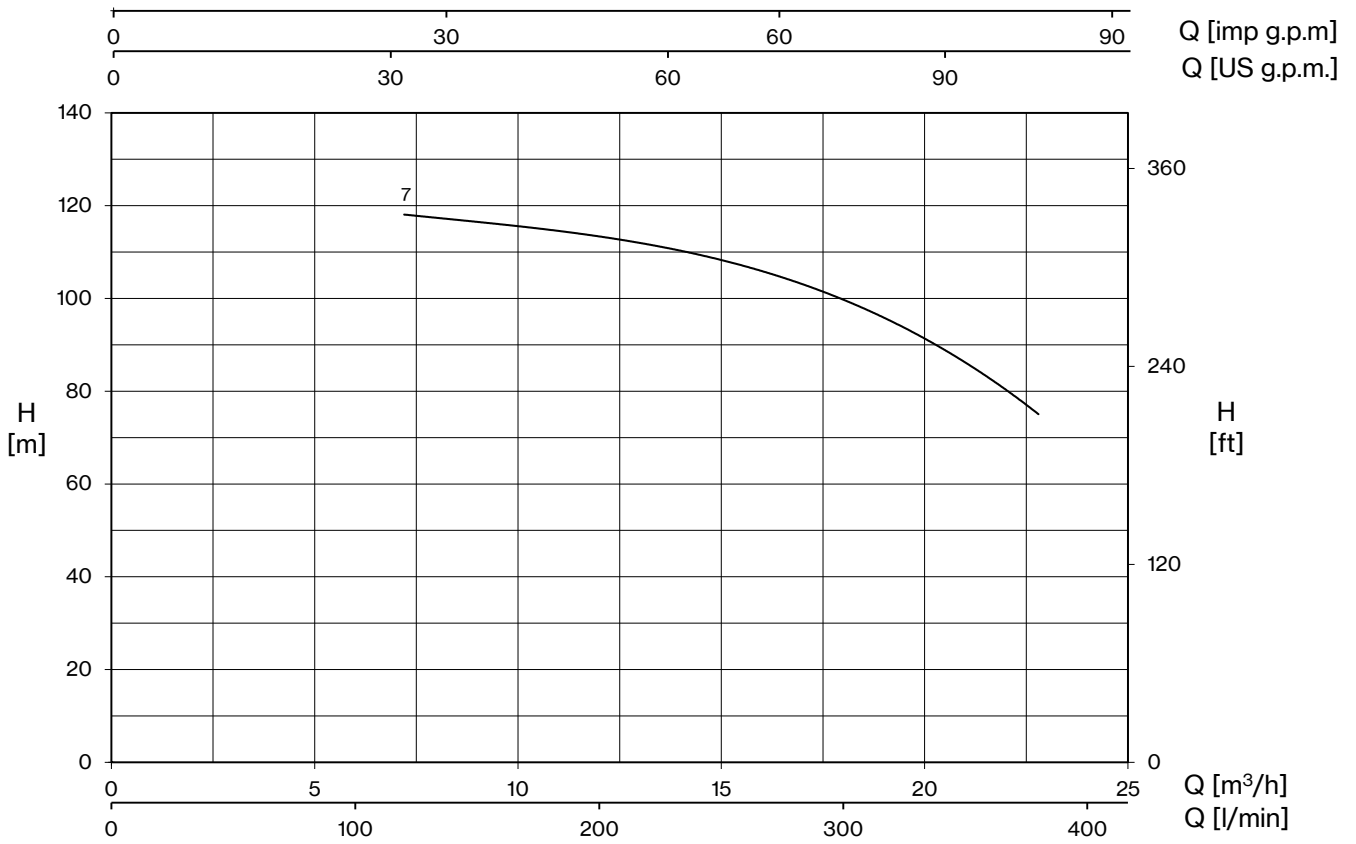

# ULTRA LG

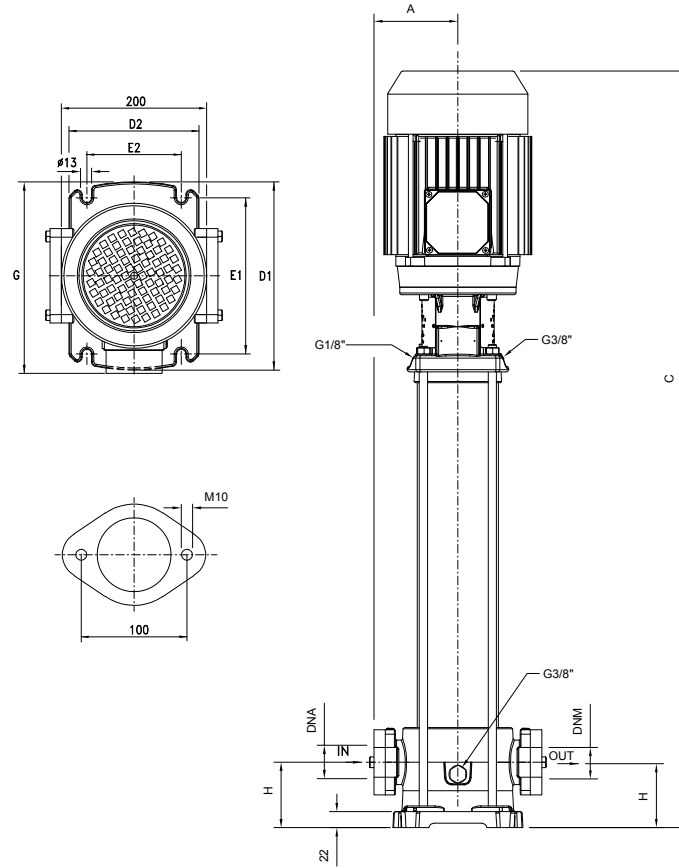



ULTRA LG	DIMENSIONS (mm)										Kg
	A	C	D1	D2	E1	E2	G	H	DNA	DNM	
U 18LG-950/7T	118	908	260	180	215	130	308	90	2" G	2" G	69,1

MODEL	LOTS			
	TRUCK		CONTAINER	
	PALLET (cm)	N° pumps	PALLET (cm)	N° pumps
U 18LG-950/7 T	100×120×150	12	100×120×150	12



# ULTRA V-SV-L-SL-LG-SLG Serie-Mechanical seal and bearings

MECHANICAL SEAL	PUMP MODEL	SHAFT Ø		STANDARD MATERIAL	OPTIONAL
	U3-120/4, U5-180/4, U7-300/4, U9-350/4, U18-400/3, U18-550/4	14mm / S	<b>Rotating face</b> <b>Stationary face</b> <b>Elastomer</b>	Graphite Ceramic EPDM	SiC SiC EPDM
	U3-150/5, U3-200/6, U3-250/7, U3-300/8, U5-250/5, U5-300/6, U5-350/7, U5-400/8, U7-400/5, U7-450/6, U7-550/7, U9-400/5, U9-450/6, U9-550/7, U9-750/8	14mm	<b>Rotating face</b> <b>Stationary face</b> <b>Elastomer</b>	Graphite SiC EPDM	SiC SiC EPDM
	U18-750/5, U18-900/6, U18-950/7, U18-1000/8	14mm / L	<b>Rotating face</b> <b>Stationary face</b> <b>Elastomer</b>	Graphite Ceramic EPDM	SiC SiC EPDM
	U3-350/10, U3-400/12, U3-450/14, U3-550/16, U5-450/10, U5-550/12, U5-750/14, U7-800/10, U7-900/12, U7-1000/14, U9-800/10, U9-900/12, U9-1000/14	14mm / Balanced seal	<b>Rotating face</b> <b>Stationary face</b> <b>Elastomer</b>	Tungsten carbide Graphite EPDM	- - -

BEARINGS	PUMP MODEL	TYPE	
	U3-120/4	6202-ZZ	6302-ZZ C3
	U3-150/5, U3-200/6, U3-250/7, 3- U3-300/8, U 5-180/4, U5-250/5, 3- U5-300/6, 3- U7-300/4	6204-ZZ	6304-ZZ C3
	1- U3-300/8, U3-350/10, U3-400/12, 1- U5-300/6, U5-350/7, U5-400/8, 1- U7-300/4, U7-400/5, U9-350/4, U9-400/5, U18-400/3	6203-ZZ	6305-ZZ C3
	U7-450/6, U7-550/7, U9-450/6, U9-550/7, U18-550/4	6204-ZZ	6306-ZZ-C3
	U3-450/14, U3-550/16, U5-450/10	6204-ZZ	3206-ZZ C3
	U5-550/12, U5-750/14, U7-750/8, U7-800/10, U7-900/12, U9-750/8, U9-800/10, U9-900/12, U18-750/5, U18-900/6	6206-ZZ C3	3306-ZZ C3
	U7-1000/14, U9-1000/14, U18-950/7, U18-1000/8	6206-ZZ C3	3308-ZZ C3



# ULTRA+VSD

Vertical booster pump with variable speed



## DESCRIPTION

Horizontal pump of ULTRA series provided with variable speed drive EPIC or IPFC. This booster pump assure the desired pressure regardless changes on flow demand making it suitable for low or missing pressure in residential systems and industrial applications. It is required the installation of a membrane tank downstream the system.

## FEATURES

- EPIC or IPFC variable speed drive
- Vertical pump of ULTRA series
- Pressure sensor
- Cable with plug

## FUNCTIONING

If the pressure in the network drops the pump will starts and gradually speeds up to provide with the set pressure. When the water demand decreases, the pressure will rise causing the pump speed to slow down and eventually to stop the pump if demand ceases. The pump will remain on standby waiting to start at the next water demand.

## SELECTION

The table below shows the vertical ULTRA pump models available for the assembly with EPIC or IPFC. Consult the catalog at the ULTRA series for pump specifics and characteristic curves.

# ULTRA+VSD

PUMP								VSD		
TYPE	MODEL	Version						TYPE	Power system	
		V	SV	L	SL/SLX	LG	SLG/SLGX		in	out
U 3	120/4T	■	■	■	■	-	-	EPIC	1-220	3-220
		■	■	■	■	-	-	IPFC109	1-220	3-220
		■	■	■	■	-	-	IPFC306	3-380	3-380
		■	■	■	■	-	-	IPFC306-220	3-220	3-220
	150/5T	■	■	■	■	-	-	EPIC	1-220	3-220
		■	■	■	■	-	-	IPFC109	1-220	3-220
		■	■	■	■	-	-	IPFC306	3-380	3-380
		■	■	■	■	-	-	IPFC309-220	3-220	3-220
	200/6T	■	■	■	■	-	-	EPIC	1-220	3-220
		■	■	■	■	-	-	IPFC114	1-220	3-220
		■	■	■	■	-	-	IPFC306	3-380	3-380
		■	■	■	■	-	-	IPFC309-220	3-220	3-220
	250/7T	■	■	■	■	-	-	EPIC	1-220	3-220
		■	■	■	■	-	-	IPFC114	1-220	3-220
		■	■	■	■	-	-	IPFC306	3-380	3-380
		■	■	■	■	-	-	IPFC309-220	3-220	3-220
	300/8T	■	■	■	■	-	-	IPFC114	1-220	3-220
		■	■	■	■	-	-	IPFC306	3-380	3-380
■		■	■	■	-	-	IPFC314-220	3-220	3-220	
350/10T	-	-	-	-	-	■	IPFC309	3-380	3-380	
	-	-	-	-	-	■	IPFC314-220	3-220	3-220	
400/12T	-	-	-	-	-	■	IPFC309	3-380	3-380	
	-	-	-	-	-	■	IPFC314-220	3-220	3-220	
450/14T	-	-	-	-	-	■	IPFC311	3-380	3-380	
	-	-	-	-	-	■	IPFC318-220	3-220	3-220	
U 5	180/4T	■	■	■	■	-	-	EPIC	1-220	3-220
		■	■	■	■	-	-	IPFC109	1-220	3-220
		■	■	■	■	-	-	IPFC306	3-380	3-380
		■	■	■	■	-	-	IPFC309-220	3-220	3-220
	250/5T	■	■	■	■	-	-	EPIC	1-220	3-220
		■	■	■	■	-	-	IPFC114	1-220	3-220
		■	■	■	■	-	-	IPFC306	3-380	3-380
		■	■	■	■	-	-	IPFC309-220	3-220	3-220
	300/6T	■	■	■	■	-	-	IPFC114	1-220	3-220
		■	■	■	■	-	-	IPFC306	3-380	3-380
		■	■	■	■	-	-	IPFC314-220	3-220	3-220
	350/7T	■	■	■	■	-	-	IPFC309	3-380	3-380
■		■	■	■	-	-	IPFC314-220	3-220	3-220	
400/8T	■	■	■	■	-	-	IPFC309	3-380	3-380	
	■	■	■	■	-	-	IPFC314-220	3-220	3-220	
450/10T	-	-	-	-	-	■	IPFC311	3-380	3-380	
	-	-	-	-	-	■	IPFC318-220	3-220	3-220	
550/12T	-	-	-	-	-	■	IPFC314	3-380	3-380	
	-	-	-	-	-	■	IPFC325-220	3-220	3-220	
750/14T	-	-	-	-	-	■	IPFC314	3-380	3-380	
	-	-	-	-	-	■	IPFC325-220	3-220	3-220	



PUMP								VSD		
TYPE	MODEL	Version						TYPE	Power system	
		V	SV	L	SL/SLX	LG	SLG/SLGX		in	out
U 7	300/4T	■	■	■	■	-	-	IPFC114	1-220	3-220
		■	■	■	■	-	-	IPFC306	3-380	3-380
		■	■	■	■	-	-	IPFC314-220	3-220	3-220
	400/5T	■	■	■	■	-	-	IPFC309	3-380	3-380
		■	■	■	■	-	-	IPFC314-220	3-220	3-220
	450/6T	■	■	■	■	-	-	IPFC309	3-380	3-380
		■	■	■	■	-	-	IPFC318-220	3-220	3-220
	550/7T	■	■	■	■	-	-	IPFC311	3-380	3-380
		■	■	■	■	-	-	IPFC318-220	3-220	3-220
	750/8T	■	■	■	■	-	-	IPFC314	3-380	3-380
		■	■	■	■	-	-	IPFC325-220	3-220	3-220
	800/10T	-	-	-	-	-	■	IPFC318	3-380	3-380
		-	-	-	-	-	■	IPFC330-220	3-220	3-220
	900/12T	-	-	-	-	-	■	IPFC318	3-380	3-380
-		-	-	-	-	■	IPFC330-220	3-220	3-220	
U 9	350/4T	■	■	■	■	-	-	IPFC309	3-380	3-380
		■	■	■	■	-	-	IPFC314-220	3-220	3-220
	400/5T	■	■	■	■	-	-	IPFC309	3-380	3-380
		■	■	■	■	-	-	IPFC314-220	3-220	3-220
	450/6T	■	■	■	■	-	-	IPFC311	3-380	3-380
		■	■	■	■	-	-	IPFC318-220	3-220	3-220
	550/7T	■	■	■	■	-	-	IPFC311	3-380	3-380
		■	■	■	■	-	-	IPFC325-220	3-220	3-220
	750/8T	■	■	■	■	-	-	IPFC314	3-380	3-380
		■	■	■	■	-	-	IPFC325-220	3-220	3-220
800/10T	-	-	-	-	-	■	IPFC318	3-380	3-380	
	-	-	-	-	-	■	IPFC330-220	3-220	3-220	
900/12T	-	-	-	-	-	■	IPFC325	3-380	3-380	
	-	-	-	-	-	-	-	3-220	3-220	



# ULTRA+VSD

		PUMP							VSD		
TYPE	MODEL	Version							TYPE	Power system	
		V	SV	L	SL/SLX	LG	HS	HX		in	out
U 18	200/1T	-	-	-	-	-	-	■	IPFC109	1-220	3-220
		-	-	-	-	-	-	■	IPFC306	3-380	3-380
		-	-	-	-	-	-	■	IPFC306-220	3-220	3-220
	400/2T	-	-	-	-	-	-	■	IPFC114	1-220	3-220
		-	-	-	-	-	-	■	IPFC306	3-380	3-380
		-	-	-	-	-	-	■	IPFC314-220	3-220	3-220
	400/3T	■	■	■	■	-	-	-	IPFC309	3-380	3-380
		■	■	■	■	-	-	-	IPFC314-220	3-220	3-220
	550/3T	-	-	-	-	-	-	■	IPFC311	3-380	3-380
		-	-	-	-	-	-	■	IPFC318-220	3-220	3-220
	550/4T	■	■	■	■	-	-	-	IPFC311	3-380	3-380
		■	■	■	■	-	-	-	IPFC325-220	3-220	3-220
	750/4T	-	-	-	-	-	-	■	IPFC314	3-380	3-380
		-	-	-	-	-	-	■	IPFC325-220	3-220	3-220
	750/5T	■	■	■	■	-	-	-	IPFC314	3-380	3-380
		■	■	■	■	-	-	-	IPFC325-220	3-220	3-220
	900/6T	■	■	■	■	-	-	-	IPFC318	3-380	3-380
		■	■	■	■	-	-	-	IPFC330-220	3-220	3-220
	950/7T	-	-	-	-	■	-	-	IPFC318	3-380	3-380
		-	-	-	-	■	-	-	IPFC330-220	3-220	3-220
1000/5T	-	-	-	-	-	-	■	IPFC318	3-380	3-380	
	-	-	-	-	-	-	■	IPFC330-220	3-220	3-220	
1500/6T	-	-	-	-	-	-	■	IPFC325	3-380	3-380	
1500/7T	-	-	-	-	-	-	■	IPFC325	3-380	3-380	
1500/8T	-	-	-	-	-	-	■	IPFC330	3-380	3-380	
2000/9T	-	-	-	-	-	-	■	IPFC330	3-380	3-380	
2000/10T	-	-	-	-	-	-	■	IPFC330	3-380	3-380	
2000/11T	-	-	-	-	-	-	■	IPFC330	3-380	3-380	
U 22	300/1T	-	-	-	-	-	■	■	IPFC114	1-220	3-220
		-	-	-	-	-	■	■	IPFC306	3-380	3-380
		-	-	-	-	-	■	■	IPFC309-220	3-220	3-220
	550/2T	-	-	-	-	-	■	■	IPFC309	3-380	3-380
		-	-	-	-	-	■	■	IPFC318-220	3-220	3-220
	750/3T	-	-	-	-	-	■	■	IPFC314	3-380	3-380
		-	-	-	-	-	■	■	IPFC325-220	3-220	3-220
	1000/4T	-	-	-	-	-	■	■	IPFC318	3-380	3-380
-		-	-	-	-	■	■	IPFC330-220	3-220	3-220	
1500/5T	-	-	-	-	-	■	■	IPFC325	3-380	3-380	
1500/6T	-	-	-	-	-	■	■	IPFC325	3-380	3-380	
2000/7T	-	-	-	-	-	■	■	IPFC330	3-380	3-380	
2000/8T	-	-	-	-	-	■	■	IPFC330	3-380	3-380	
U 35	400/1-1RT	-	-	-	-	-	■	■	IPFC309	3-380	3-380
		-	-	-	-	-	■	■	IPFC314-220	3-220	3-220
	550/1T	-	-	-	-	-	■	■	IPFC311	3-380	3-380
		-	-	-	-	-	■	■	IPFC318-220	3-220	3-220
	750/2-2RT	-	-	-	-	-	■	■	IPFC314	3-380	3-380
		-	-	-	-	-	■	■	IPFC325-220	3-220	3-220
	1000/2-1RT	-	-	-	-	-	■	■	IPFC318	3-380	3-380
		-	-	-	-	-	■	■	IPFC330-220	3-220	3-220
	1500/2T	-	-	-	-	-	■	■	IPFC325	3-380	3-380
	1500/3-2RT	-	-	-	-	-	■	■	IPFC325	3-380	3-380
1500/3-1RT	-	-	-	-	-	■	■	IPFC325	3-380	3-380	
2000/3T	-	-	-	-	-	■	■	IPFC325	3-380	3-380	
2000/4-2RT	-	-	-	-	-	■	■	IPFC330	3-380	3-380	
2000/4-1RT	-	-	-	-	-	■	■	IPFC330	3-380	3-380	



PUMP									VSD		
TYPE	MODEL	Version							TYPE	Power system	
		V	SV	L	SL/SLX	LG	HS	HX		in	out
U 50	750/1-1RT	-	-	-	-	-	■	■	IPFC311	3-380	3-380
		-	-	-	-	-	■	■	IPFC325-220	3-220	3-220
	1000/1T	-	-	-	-	-	■	■	IPFC314	3-380	3-380
		-	-	-	-	-	■	■	IPFC325-220	3-220	3-220
	1500/2-2RT	-	-	-	-	-	■	■	IPFC325	3-380	3-380
	1500/2-1RT	-	-	-	-	-	■	■	IPFC325	3-380	3-380
2000/2T	-	-	-	-	-	■	■	IPFC330	3-380	3-380	
U 75	1000/1-1RT	-	-	-	-	-	■	■	IPFC314	3-380	3-380
		-	-	-	-	-	■	■	IPFC325-220	3-220	3-220
	1500/1T	-	-	-	-	-	■	■	IPFC325	3-380	3-380
	2000/2-2RT	-	-	-	-	-	■	■	IPFC330	3-380	3-380
U 90	1500/1-1RT	-	-	-	-	-	■	■	IPFC325	3-380	3-380
	2000/1RT	-	-	-	-	-	■	■	IPFC330	3-380	3-380