

DTR/DTRT

Drainage
Grinder



DTR 150-300

DTRT 400-1000

DTRT 400-1000/P

Drainage and waste water pumps equipped with open impeller and grinder system able to shred sewage with suspended solids and prevent the pump from clogging. Best for emptying of septic tanks and residential sumps as well as for rain water systems and for draining of flooded areas where seamless operation is required. The quick coupling feet DN50 and DN65 is available for flanged pumps.

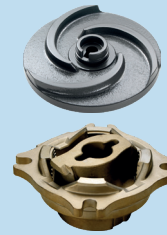

Grey water



Black water

Construction features

Pump body cast iron

Impeller cast iron

Mechanical seal double seal with oil barrier: silicon carbide on pump side, ceramic-graphite on motor side

Motor shaft stainless steel AISI 304

Max submergence max 20 m

Liquid temperature 0 - 40 °C



Grinder treated stainless steel

Bolts A2 stainless steel

Foot support galvanized iron

Gaskets NBR rubber

Motor

3- 230V-50Hz

3- 400V-50Hz

3- 230/400V-50Hz

3- 400/690V-50Hz

2 Poles induction motor

1- 230V-50Hz

run capacitor (35µF for 1,5HP models, 50µF for 2HP model) + start capacitor (80µF with disjuntor) required

Insulation class F

Protection degree IPX8

TYPE	LOTS			
	TRUCK		CONTAINER	
	PALLET (cm)	N° pumps	PALLET (cm)	N° pumps
DTRT 150-300	85×110×145	18	85×110×190	27
DTRT 400-550	85×110×170	12	85×110×170	12
DTRT 750-1000	100×120×190	12	100×120×190	12



DTR/DTRT

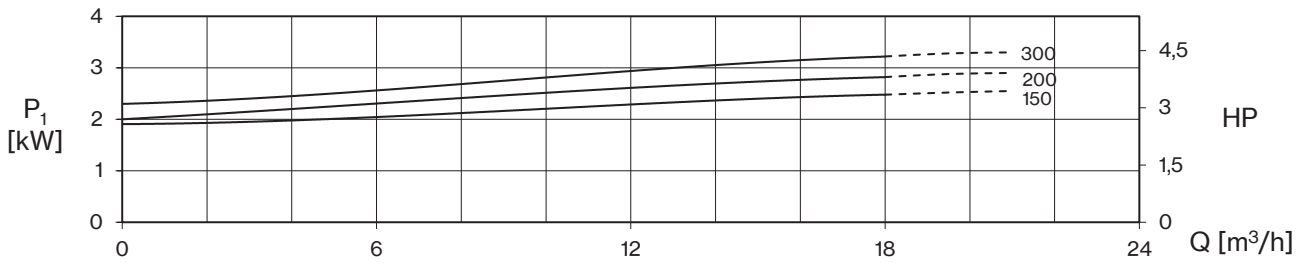
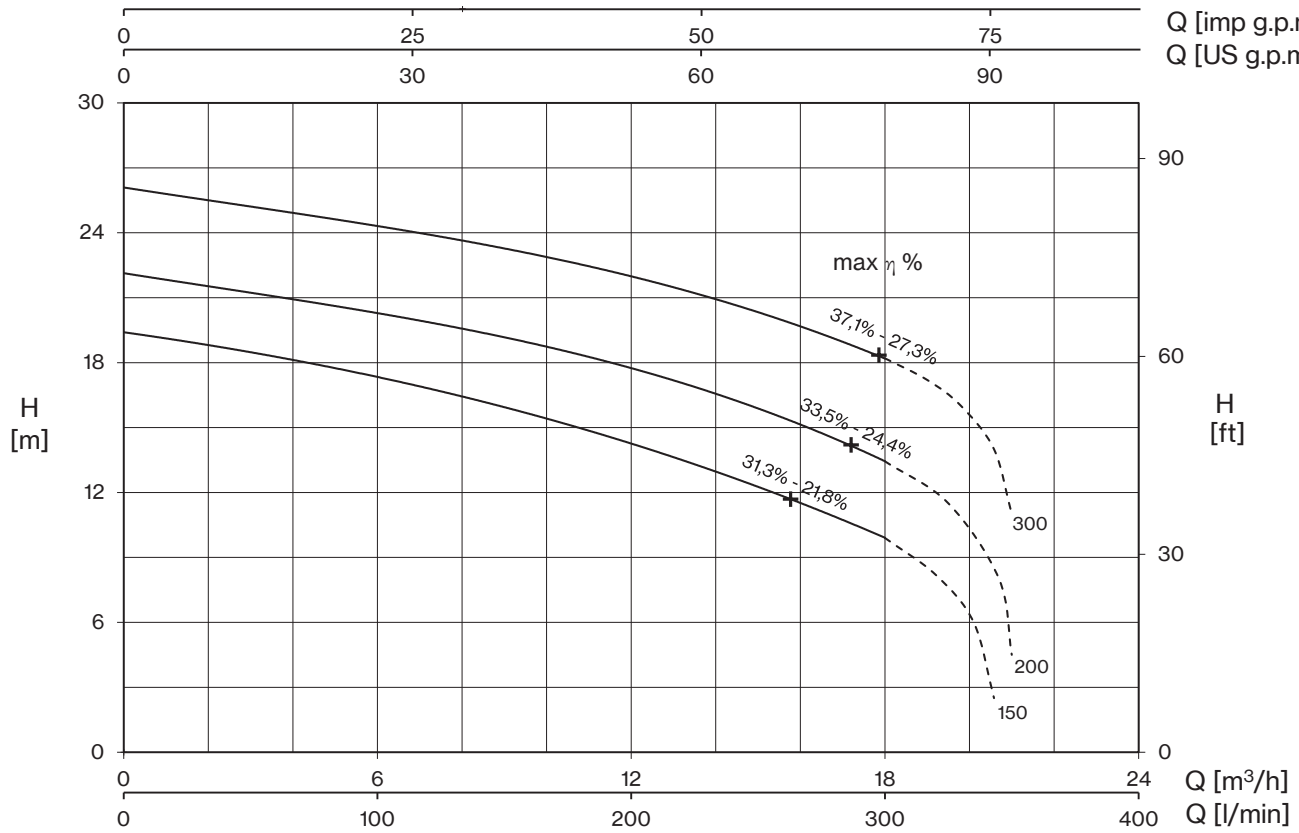

TYPE		AMPERE				
1~	3~	230 V 50 Hz	3x230 V 50 Hz (*)	3x400 V 50 Hz	230/400 V 50 Hz λ/Δ (*)	400/690 V 50 Hz λ/Δ
DTR 200	DTRT 200	13,6	8,8	5,1	-	-
-	DTRT 300	-	10	5,8	-	-

+ max η %

max hydraulic efficiency and respective total efficiency

(*) no standard execution

TYPE		P2		P1 (kW)		Q (m³/h - l/min)							
1~	3~	HP	kW	1~	3~	0	3	6	9	12	13,2	15	18
						0	50	100	150	200	220	250	300
						H (m)							
DTR 150	DTRT 150	1,5	1,1	2,6	2,5	19,4	18,5	17,3	16,0	14,2	13,5	12,3	9,9
DTR 200	DTRT 200	2	1,1	3	2,8	22,1	21,3	20,3	19,1	17,7	17,1	16	13,4
-	DTRT 300	3	2,2	-	3,2	26,1	25,2	24,3	23,3	22	21,4	20,3	18,2



DTR/DTRT

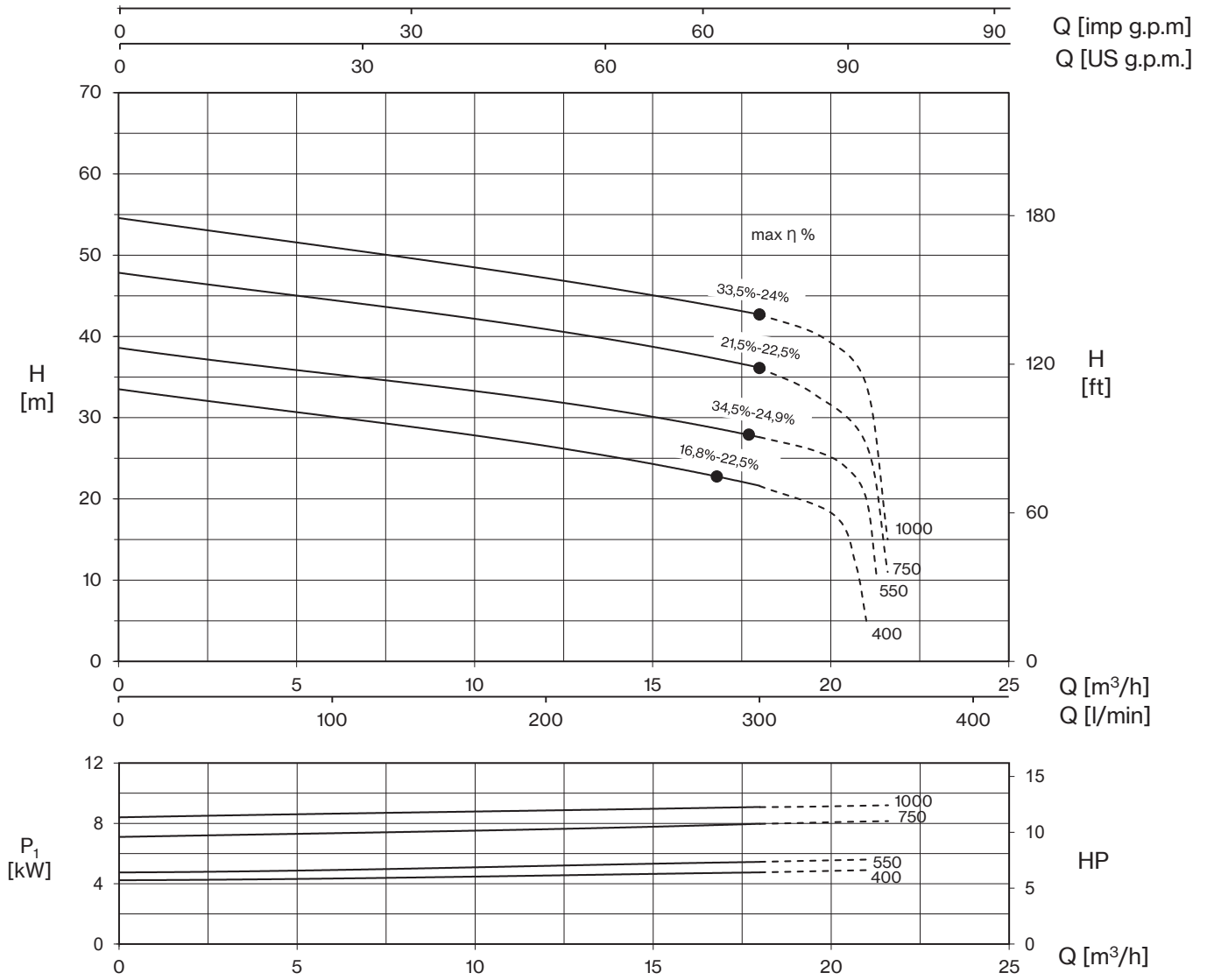

TYPE	AMPERE			
	3~ 3x230 V 50 Hz (*)	3~ 3x400 V 50 Hz	230/400 V 50 Hz λ / Δ (*)	400/690 V 50 Hz λ / Δ
DTRT 400	13,0	7,5	-	-
DTRT 550	15,9	9,2	-	-
DTRT 750	-	13,9	24	13,9
DTRT 1000	-	15,5	26,8	15,5

+ max η %

max hydraulic efficiency and respective total efficiency

(*) no standard execution

TYPE	P2		P1 (kW)	Q (m³/h - l/min)									
				0	3	6	9	12	15	18	21	21,6	
	HP	kW	3~	0	50	100	150	200	250	300	350	360	
DTRT 400	4	3	4,5	33,5	31,8	30,1	28,5	26,4	24,4	21,6			
DTRT 550	5,5	4	5,3	38,6	36,9	35,3	33,9	32,1	30,1	27,6			
DTRT 750	7,5	5,5	8,0	47,8	46,2	44,5	42,7	40,8	38,9	36,1	26,7	11,0	
DTRT 1000	10	7,5	9,1	54,6	52,7	51,0	49,2	47,1	45,1	42,7	34,0	15,0	



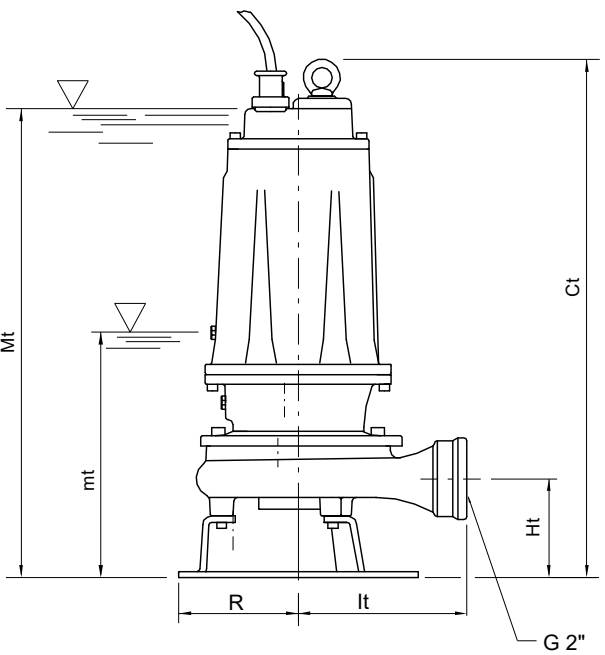

mt/mf: minimum working level
 Mt/Mf: minimum submergence level for continuous duty

TYPE	DIMENSIONS (mm)							Kg
	Ct	Ht	R	lt	mt	Mt	DNM	
DTR 150-DTRT 150	513	102	117	174	205	475	2"G	38
DTR 200-DTRT 200	513	102	117	174	205	475	2"G	38,5
DTRT 300	513	102	117	174	205	475	2"G	38

TYPE	PROTECTION		1 PUMP CONTROL PANEL			2 PUMPS CONTROL PANEL		
	1 x 230 V	3 x 400 V	1 x 230 V	3 x 400 V	400 / 690 V	1 x 230 V	3 x 400 V	400 / 690 V
DTR 150	PMLD 15/35-13	PT 20-30-40/4.3-6.8	EQSM + 35µF + 80µF*	EQSMT 10		EQ2SM + 2x35µF + 2x80µF*	EQ2SMT 10	
DTR 200	PMLD 20/50-15	PT 20-30-40/4.3-6.8	EQSM + 50µF + 80µF*	EQSMT 10		EQ2SM + 2x50µF + 2x80µF*	EQ2SMT 10	
DTRT 300		PT 20-30-40/4.3-6.8		EQSMT 10			EQ2SMT 10	
DTRT 400		PT 40-50/5.7-9.1		EQSMT 10			EQ2SMT 10	
DTRT 550		PT 55-75/8.6-13.5		EQSMT 10			EQ2SMT 10	
DTRT 750		PT 100/12.5-16.5		EQSMT 10	QST 7		EQ2SMT 10	Q2ST 7
DTRT 1000		PT 125-150/16-21		EQSMT 10	QST 10		EQ2SMT 10	Q2ST 10

*start capacitor with disjuntor

DTR/DTRT

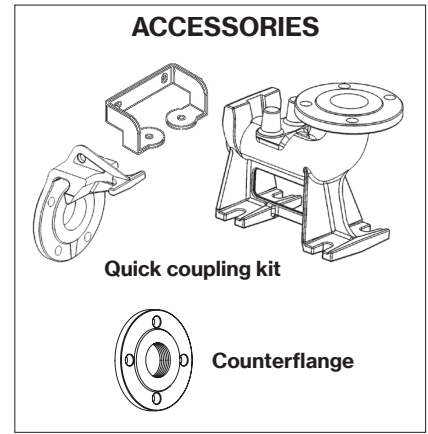
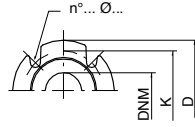
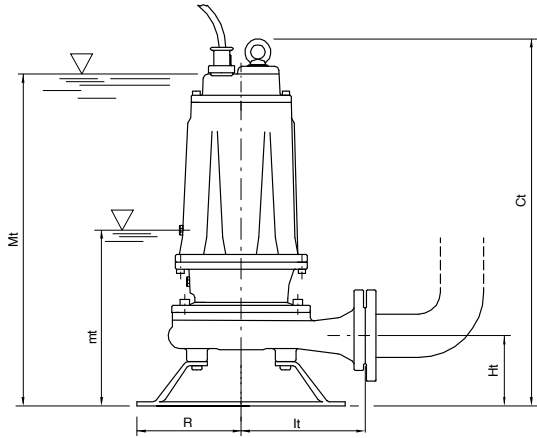

TYPE	DIMENSIONS (mm)							Kg
	Ct	Ht	R	lt	mt	Mt	DNM	
DTRT 400	595	112	160	190	265	550	50	62,5
DTRT 550	595	112	160	190	265	550	50	65,5
DTRT 750	680	160	180	250	280	630	65	91,5
DTRT 1000	680	160	180	250	280	630	65	94,5

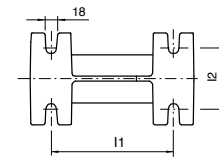
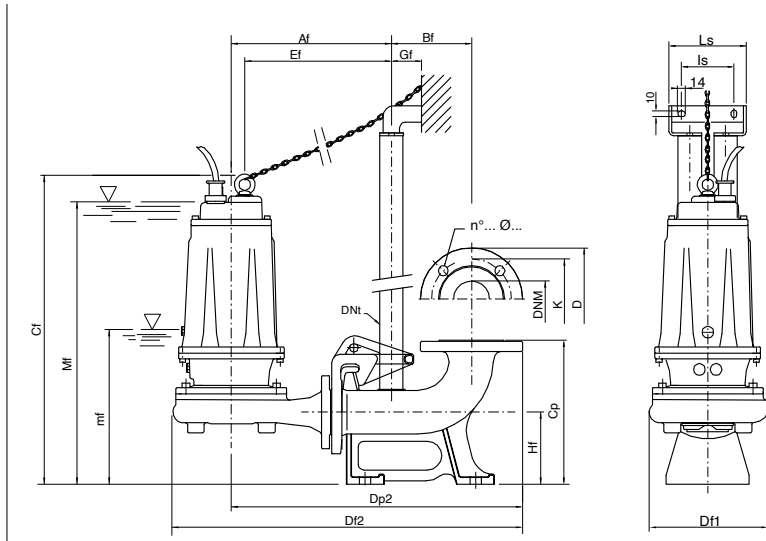

mt/mf: minimum working level
Mt/Mf: minimum submergence level for continuous duty

TYPE	DIMENSIONS (mm)																		
	Af	Bf	Cf	Cp	Df1	Df2	Dp2	Dnt	Ef	Gf	Hf	I1	I2	Is	Ls	mf	Mf	DNM	
DTRT 400/P	300	145	614	260	237	654	538	1" 1/4	269	55	130	200	100	95	140	290	566	50	
DTRT 550/P	300	145	614	260	237	654	538	1" 1/4	269	55	130	200	100	95	140	290	566	50	
DTRT 750/P	331	145	656	260	279	710	569	1" 1/4	297	55	130	200	100	95	140	290	600	65	
DTRT 1000/P	331	145	656	260	279	710	569	1" 1/4	297	55	130	250	100	95	140	290	600	65	

Flange UNI PN 10 (mm)			
DNM	K	D	n°... Ø...
50	125	165	4... 18...
65	145	185	4... 18...

