



Drainage pump with "Double-Channel" impeller for pumping waste waters and liquids with suspended solids; ideal for civil and household applications.



Construction features

Pump body cast iron

Shell, motor cover, base support stainless steel



Impeller stainless steel

Mechanical seal double seal with oil barrier: silicon carbide on pump side, sealing ring on motor side

Motor shaft stainless steel AISI 430

Free passage Ø max 50 mm

Max submergence max 5 m

Liquid temperature 0 - 40 °C

Cable H05 RN8F, 10 m

G float switch

Motor

3~ 3x400V-50Hz

2 Poles induction motor 1~ 1x230V-50Hz
(with thermal protection)

Insulation class F

Protection degree IPX8

TYPE	LOTS			
	TRUCK		CONTAINER	
	PALLET (cm)	N° pumps	PALLET (cm)	N° pumps
DB	80×120×160	51	80×120×160	51

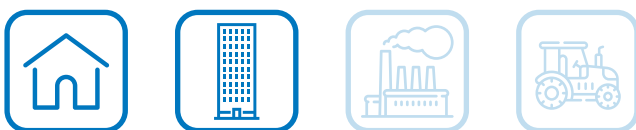

DB

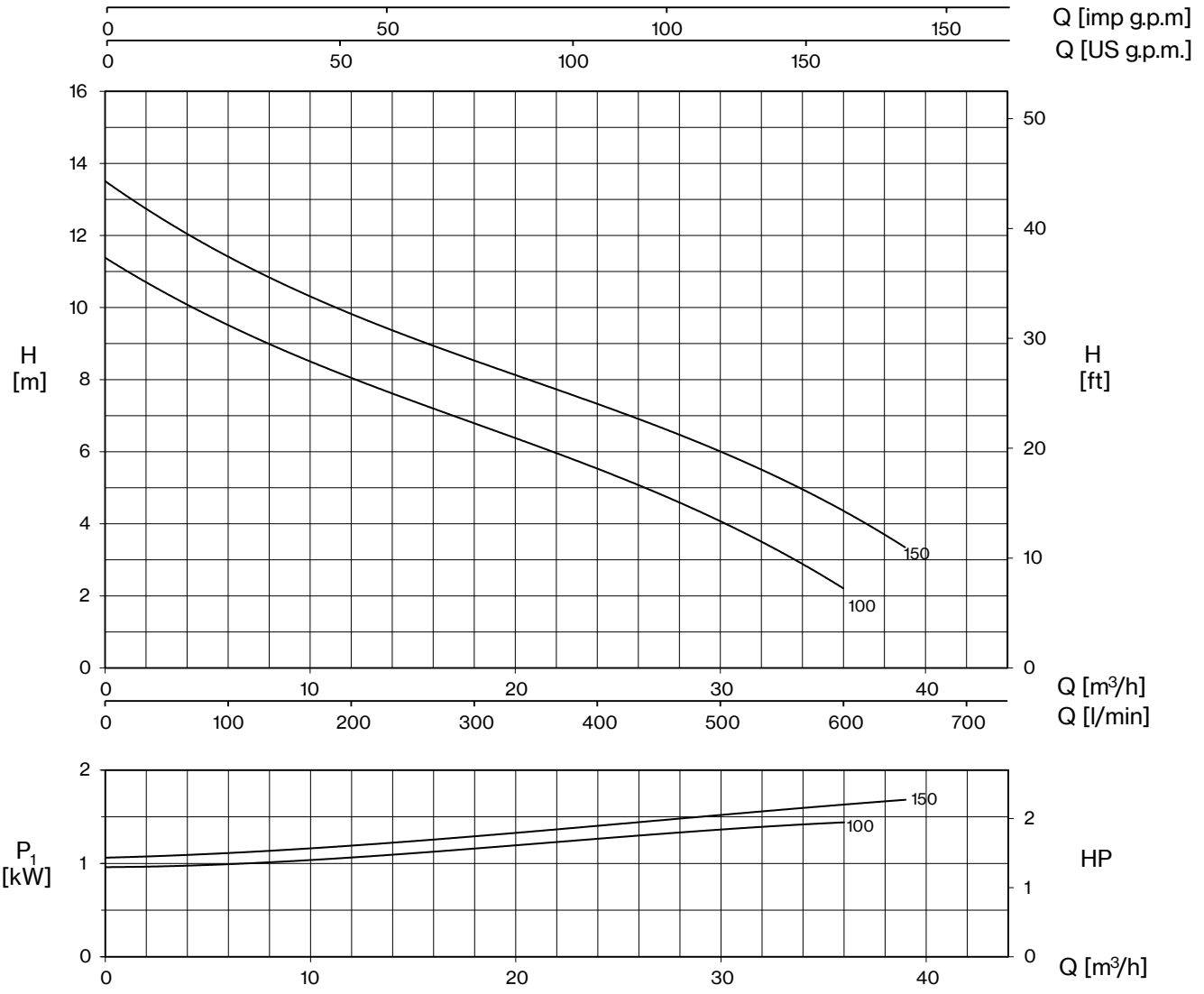

TYPE		W	AMPERE		Q (m³/h - l/min)									
1~	3~		1~	3~	0	6	12	18	24	30	36	39		
					0	100	200	300	400	500	600	650		
				1x230 V 50 Hz	3x400 V 50 Hz		H (m)							
DB 100 (G)	DBT 100	1350	5,9	2,8	11,4	9,5	8,0	6,8	5,6	4,0	2,2			
DB 150 (G)	DBT 150	1700	8,0	3,0	13,6	11,5	9,8	8,5	7,3	6,0	4,3	3,4		

E: maximum emptying level
Mt: minimum liquid level for continuous duty

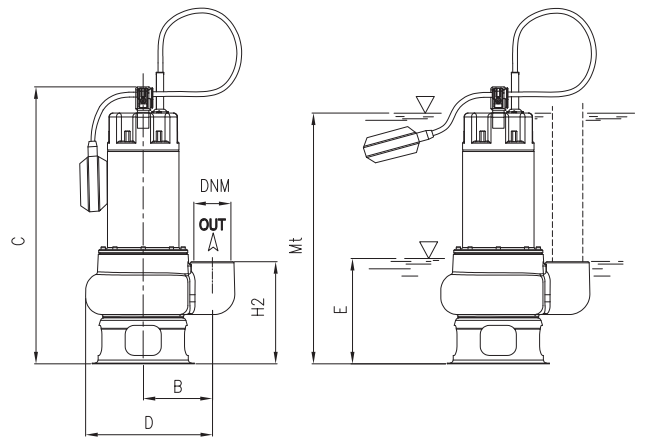

TYPE	DIMENSIONS (mm)										Kg
	B	C	D	E	H2	Mt	DNM	I	L	M	
DB 100 (G)	142,5	461	247,5	185	170	390	2" G	200	260	470	17
DB 150 (G)	142,5	461	247,5	185	170	390	2" G	200	260	470	18,5

