



RPM	MODELLO MODEL	PORTATA FLOW		PRESSIONE PRESSURE		POTENZA POWER		PESO WEIGHT
		l/min	GPM	bar	PSI	HP	kW	Kg
1000	PENTA-B 25/350 R-L	25	6.6	350	5075	22.4	16.5	43.8
	PENTA-B 25/400 R-L	25	6.6	400	5800	25.6	18.8	43.8
	PENTA-B 30/300 R-L	30	7.9	300	4350	23.1	17.0	43.8
	PENTA-B 40/250 R-L	39	10.3	250	3625	25.0	18.4	43.8
	PENTA-B 40/300 R-L	40	10.6	300	4350	30.7	22.6	43.8
	PENTA-B 50/200 R-L	49	12.9	200	2900	25.1	18.5	43.8
1450	PENTA-C 35/350 R-L	35	9.2	350	5075	31.4	23.1	43.8
	PENTA-C 35/400 R-L	35	9.2	400	5800	35.9	26.4	43.8
	PENTA-C 43/300 R-L	43	11.4	300	4350	33.1	24.3	43.8
	PENTA-C 55/250 R-L	57	15.1	250	3625	36.5	26.8	43.8
	PENTA-C 58/300 R-L	58	15.3	300	4350	44.6	32.8	43.8
	PENTA-C 70/200 R-L	71	18.8	200	2900	36.4	26.8	43.8

R = Presa di Forza Destra
R = Right PTO Shaft

L = Presa di Forza Sinistra
L = Left PTO Shaft

Sono disponibili modelli con
Doppia Presa di Forza
Double PTO Shaft models
are available

Dimensioni d'ingombro (mm) - Overall Dimensions (mm)

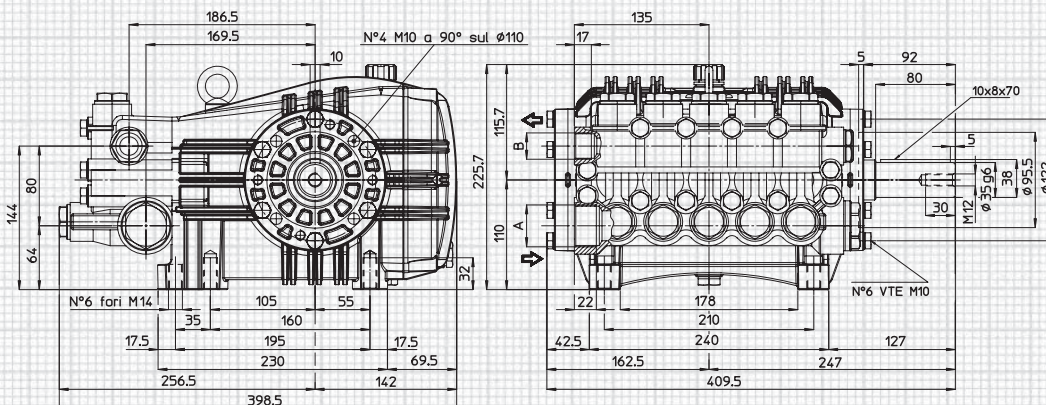

	A (IN)	B (OUT)
PENTA-B 25/350 R-L		
PENTA-B 25/400 R-L	G 1"	G 1/2"
PENTA-C 35/350 R-L		
PENTA-C 35/400 R-L		
PENTA-B 30/300 R-L		
PENTA-B 40/250 R-L		
PENTA-B 40/300 R-L		
PENTA-B 50/200 R-L	G 1 1/4"	G 3/4"
PENTA-C 43/300 R-L		
PENTA-C 55/250 R-L		
PENTA-C 58/300 R-L		
PENTA-C 70/200 R-L		